

innermost[®]





In 1999 Central London, Steve Jones and Russell Cameron gave up their jobs within design consultancy and furniture design to pursue a shared dream of a unique but diverse furniture and lighting brand.

From their humble beginning in an old lighting factory in Wembley, North London, they had worked with designers from across the globe who called London their home. And still today they continue to embrace that vivid diversity, striving to be 'as British as London itself' – that is to say very British and yet highly adaptable and with a global vision. Their quirky and rebellious approach to design is driven by high-spirited London culture.

This is the story of a culture with greatly antagonistic qualities – on the one hand, classical English tradition and on the other, the tumultuous punk culture. And innermost exists in the coming together of these heterogeneous elements, purveying taste and quality with a non-conformist attitude.

We are **Concept**. We are **Quality**. We are **Wit**.

WE ARE INNERMOST.











SUSPENSION



Core 12



Jelly 13



Boule 14-15



Pomelo 16



Drop 17



Circus 18-21



Glaze 22-25



Stupa 26-29



Facet 30-33



Beads 34-39



Membrane 40-43



Bubble 44-47



Buckle 48-51



Matrioshka 52-53



Snowdrop 54-55



Asteroid 56-59



Gable 60-61



Latitude 62-63



Portland 64-67



Jeeves & Wooster
68-71

WALL LAMP



Cobra 74-75



Circus Wall 76-77



Bolt 78



Bracket 79



YOYWall 80-81

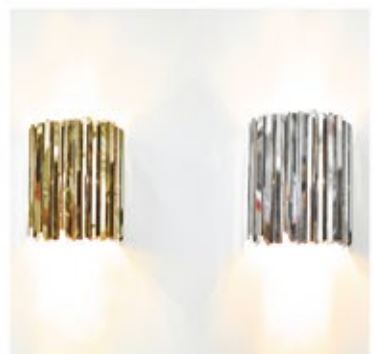

Facet Wall 82

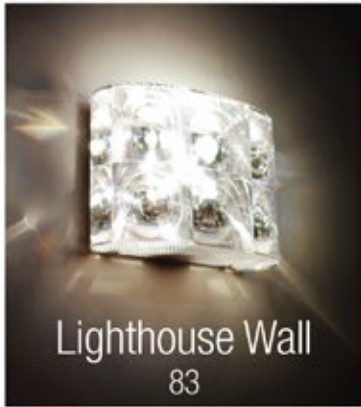

Lighthouse Wall
83



Jeeves Wall
84-85

TABLE & FLOOR



Lateralis 88-89



Asteroid Table
90-91



Parasol 92-93



YOYLight
94-95



Jeeves Table
96-97



RD2SQ
98-99

LAMPSHADES, BASES & FITTINGS



Moscow Graffiti
103

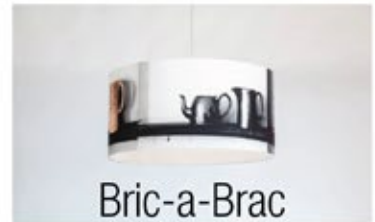

Bric-a-Brac
104



Laurie Grove
105



Lighthouse
106-111



Dent
112-113



Kapow! 114-115



RD2SQ
116-117



MnM
118-121



Cork
122-123



Kobe
124-127



Metallic 128-130



Trumpet Base 131

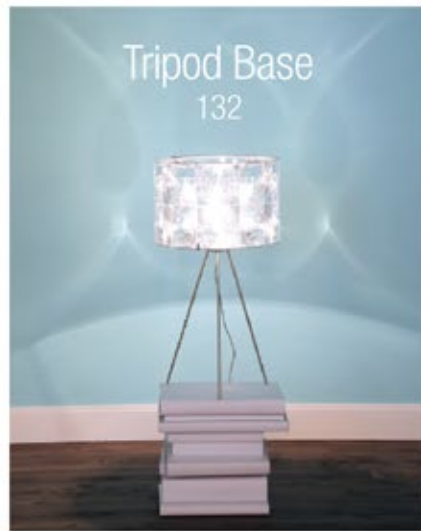

Tripod Base
132



Pendant Fittings 133

FURNITURE



Origami
136-139



Canvas 140-145



Poke Stool 146-149



HiHo 150-153

SPECIFICATION

154-185

CONTACT

186-187

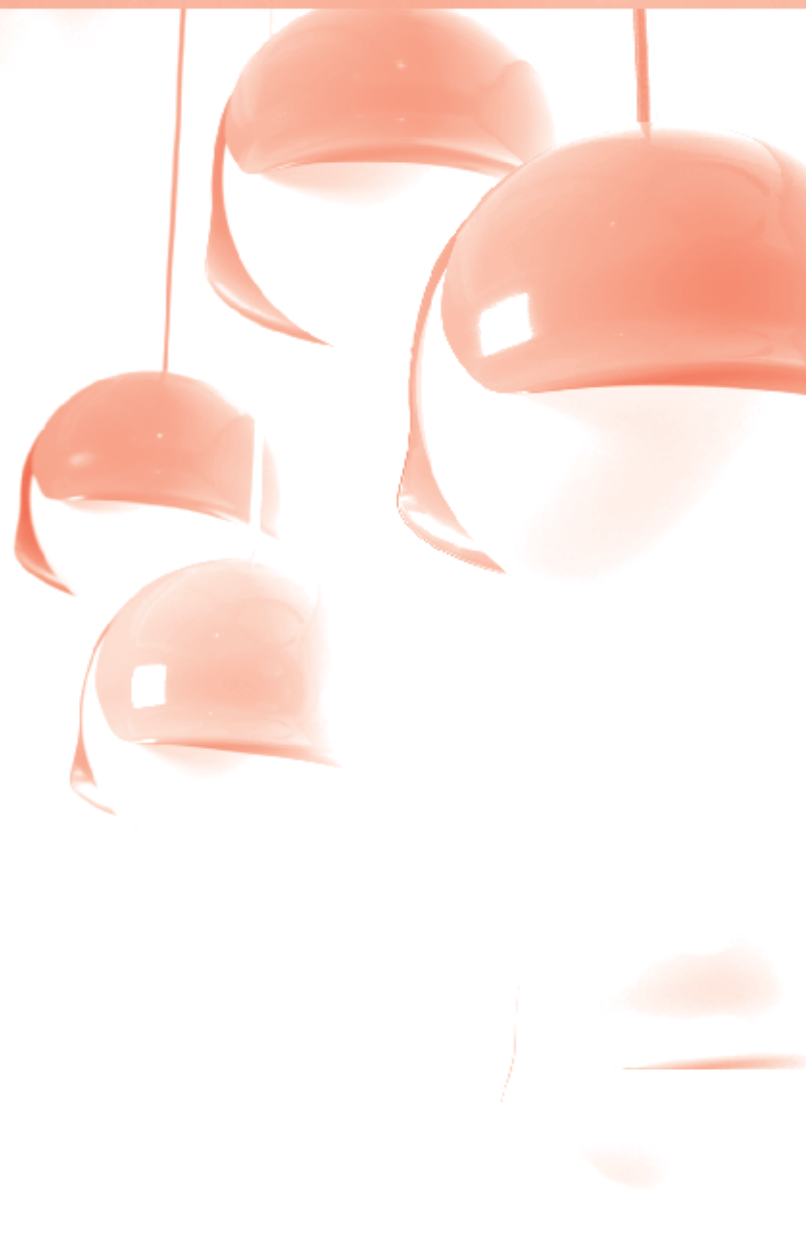



SUSPENSION



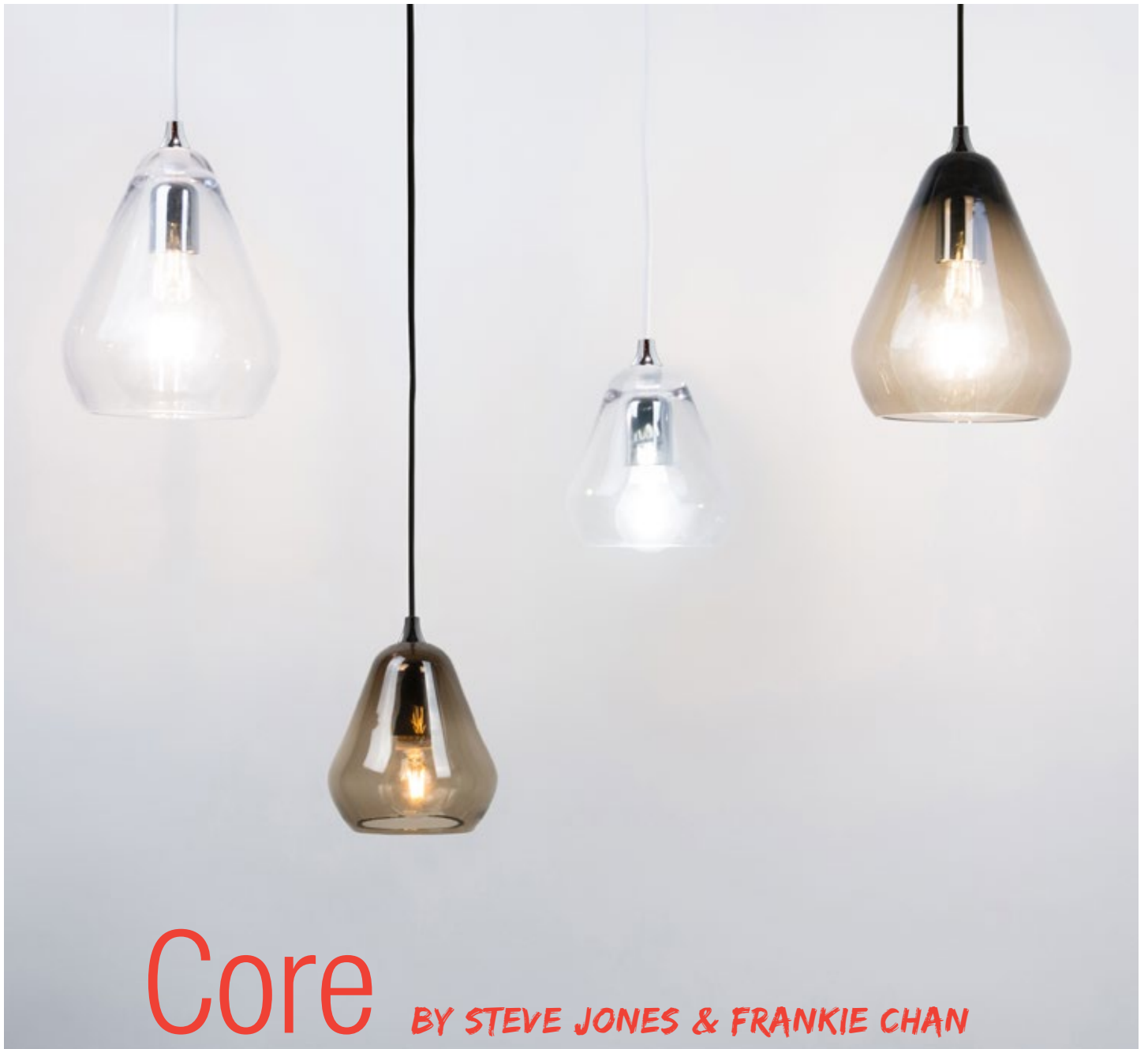

Core was designed by Steve Jones and Frankie Chan from innermost. It resembles a parison of molten glass, fresh from the furnace, its form still slowly being shaped by gravity's pull.

Material: Glass

Core 15

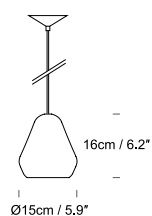

Core 20

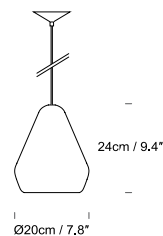



Jelly BY STONE DESIGNS

Transparent hand blown glass shades that seem to quiver in the light, colourful Jelly is a treat for the eyes.

With four colours across two sizes, the collection truly comes alive when mixed and matched together.

Material: Glass

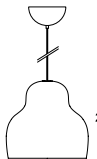
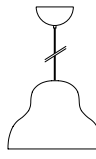
<ul style="list-style-type: none"> Grey-05 Red-08 Blue-12 Yellow-27 	<p>Jelly 22</p>  <p style="text-align: right; margin-right: 10px;">20cm / 7.9"</p> <p style="text-align: center; margin-top: 5px;">Ø22cm / 8.6"</p>	<p>Jelly 24</p>  <p style="text-align: right; margin-right: 10px;">17cm / 6.7"</p> <p style="text-align: center; margin-top: 5px;">Ø24cm / 9.4"</p>
--	---	--



Boule

BY INNERMOST

In the classic finishes of innermost best-seller – Beads, this is one small Boule with a great impact!

Material: Steel

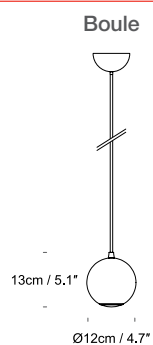
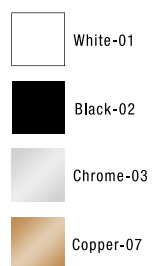

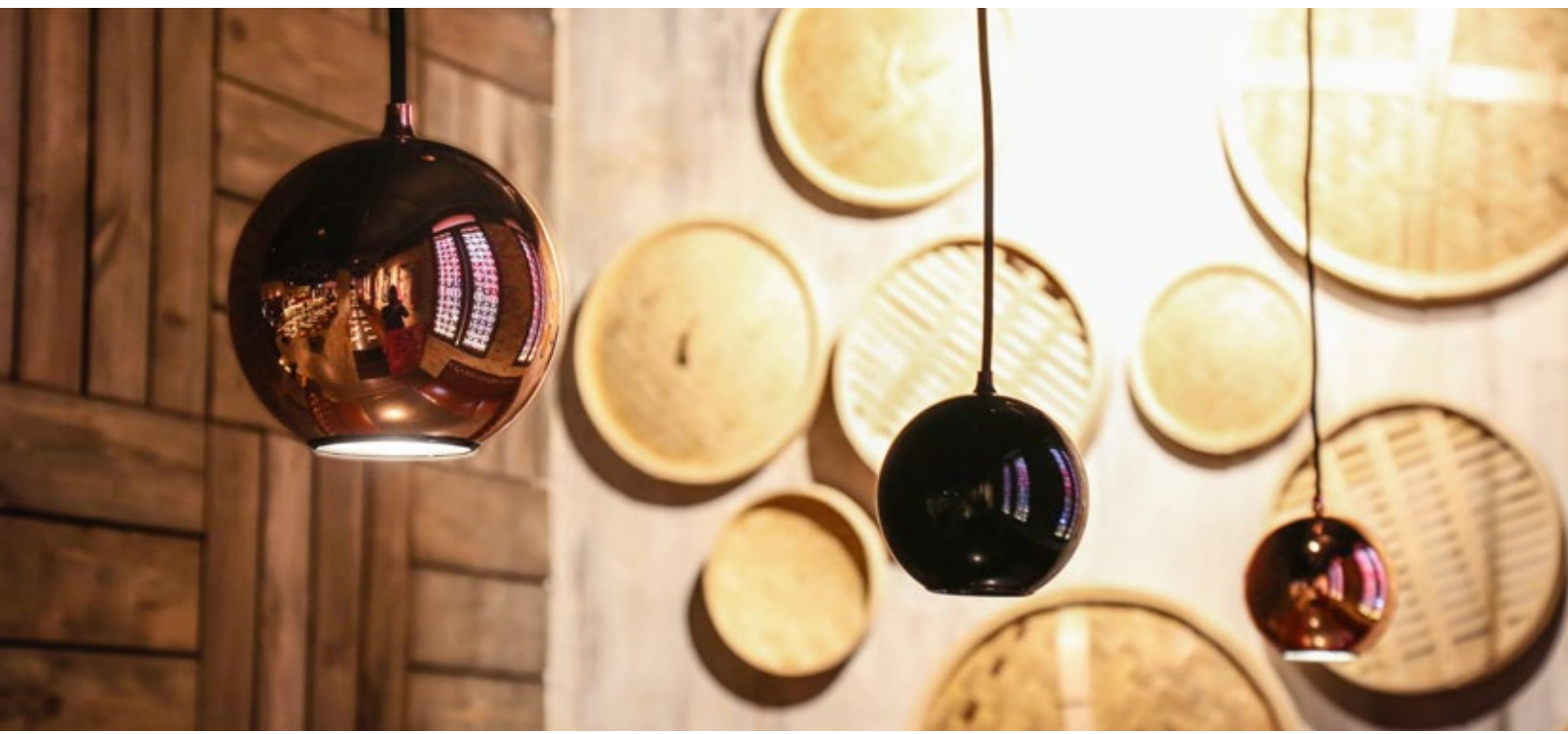

Hei House, Wanchai, Hong Kong
Design: Regal Power Holdings
Photography by VG Media





From innermost's Essentials Collection, Pomelo is deliberately subtle. A quiet diffusion of light in white opal glass. Its stately, voluptuous form provides an ambient effect with a sculptural twist.

Material: Glass

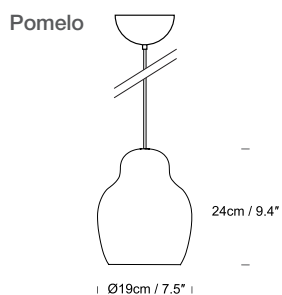

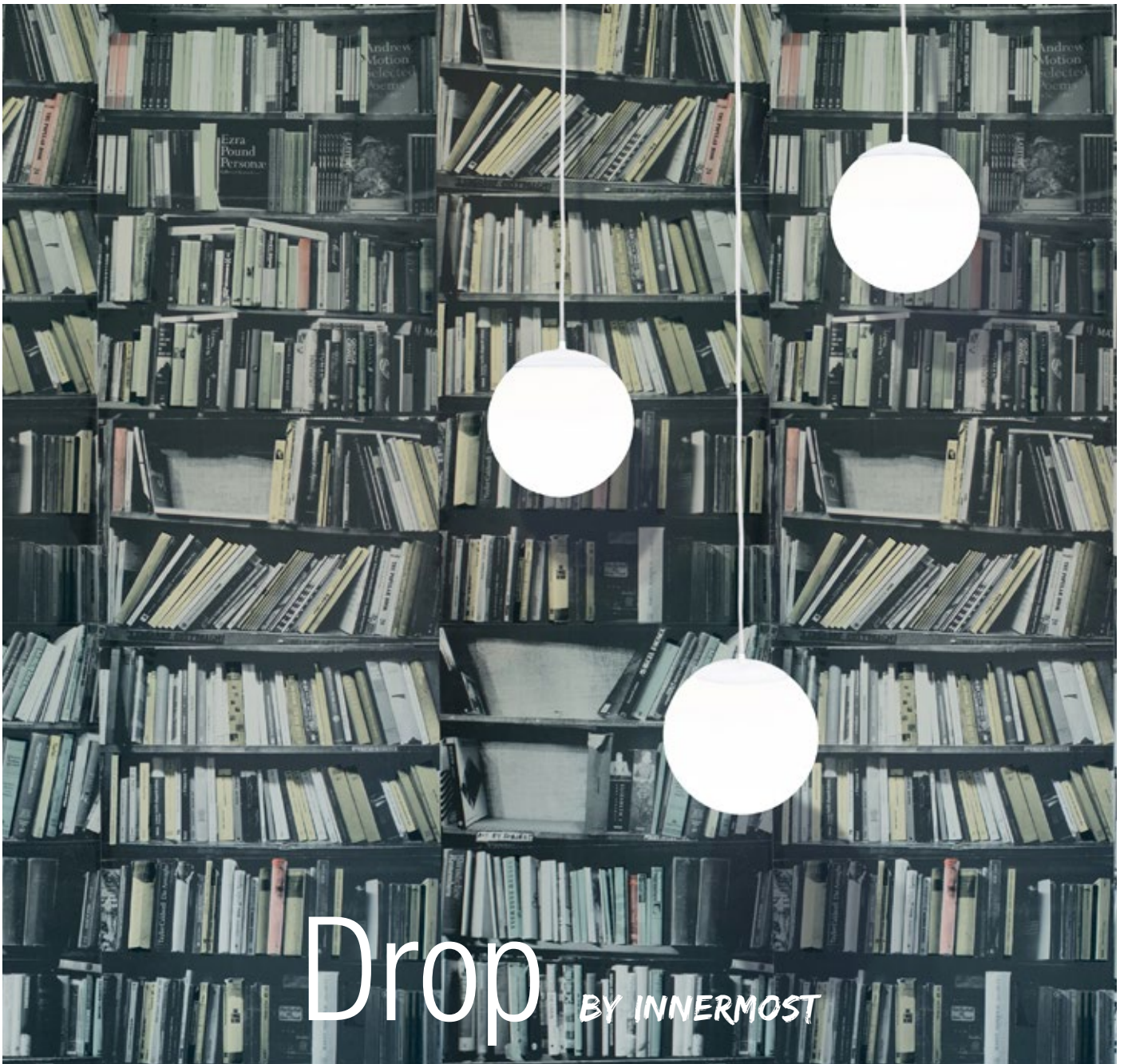

Drop is a white frosted glass globe delicately topped with a white powder coated stainless steel cap. Resembling a drop of pristine pearl, it is reminiscent of the flourishes of the mid-century.

Material: Glass & Stainless Steel

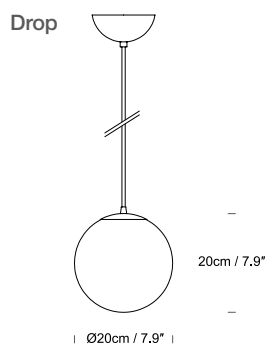





Circus

BY CORINNA WARM

Berlin born, London based Corinna Warm based these beautiful pendants on the shape of Victorian Circus tents.



See P.76 for the matching wall lamp.



Staybridge Hotel, London, England Photographer: Hufton & Crow Ltd

Client: CLS Holdings PLC



The Marker Hotel, Dublin, Ireland
Architect: McCauley Daye O'Connell Architects Limited

Material: Aluminium



White with Antique Gold Interior-01



Black with Antique Gold Interior-02



Grey with Matt White Interior-04

Circus 15

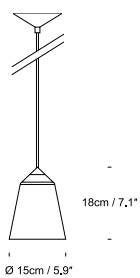

Circus 36

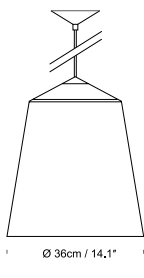

Circus 56

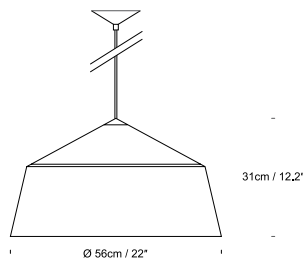

DF/Mexico Diner, London, England
Designer: Softroom Architecture and Design, London
Co-Creator: Wahaca Restaurants



Mint Velvet, Guildford, England
Photographer: Pelican Images



Private Residence, Spottiswoode 18, Singapore



UXC, Sydney, Australia Design: Insight Projects



Moore Park Gardens, Sydney, Australia
Design: Alexandra Kidd Design
Photography: Will Horner



Glaze

BY CORINNA WARM

At first glance Glaze appears to seamlessly fuse delicate sections of metal and porcelain. Yet this fusion of craft and industry is not as it might appear.

Finish options provide contrast- warm copper kitchen tones against a smooth white 'ceramic' finish, or harder edged versions with graphite anodising.

These pendants are as at home in a classic kitchen or dining interior as they are in a contemporary bar or restaurant.





Mr. Meat Hot Pot & Butchery, Taipei, Taiwan
Designer: 33 Interior
Photographer: Rudy Wu





Glaze 32

Glaze 56

Glaze 33

Material: Aluminium



Cream & Copper-07



Black & Charcoal-51

Glaze 14

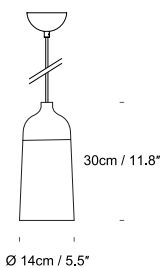

Glaze 33

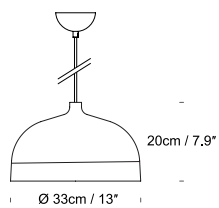

Glaze 32

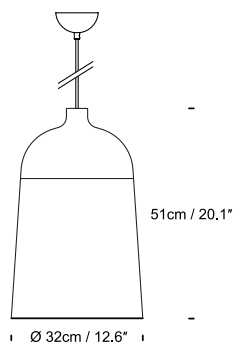

Glaze 56

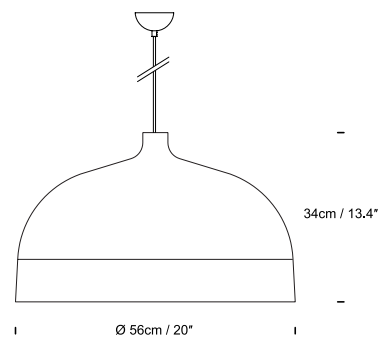

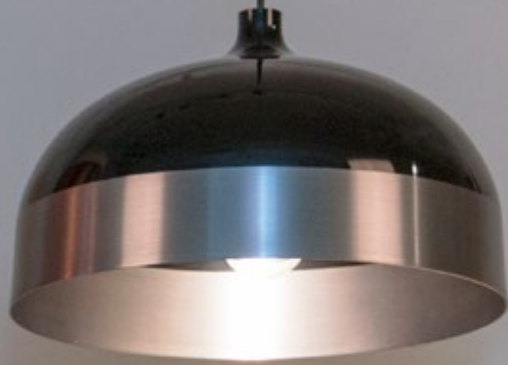

Glaze 33



Glaze 14



Glaze 56



Stupa BY FRESHWEST

Yo! Sushi, Chelmsford, England
Designer: Philip Watts Design



Cast from resin, the individual pieces that make up Stupa are joined and hand finished individually on a lathe, then polished with beeswax.

This combination of a mass production process with a high value hand skilled element makes for wonderful and interesting lighting; in this instance, the result is a lamp that permeates an ambient glowing warmth while still providing a practical light level.

The form was inspired by temple architecture in Asia, particularly the stupas of Myanmar.

Winner of Good Design Award 2015



Material: Resin



Stupa 18

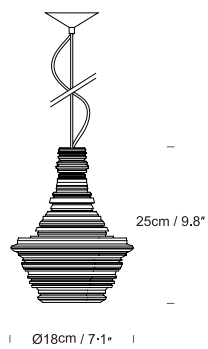

Stupa 56

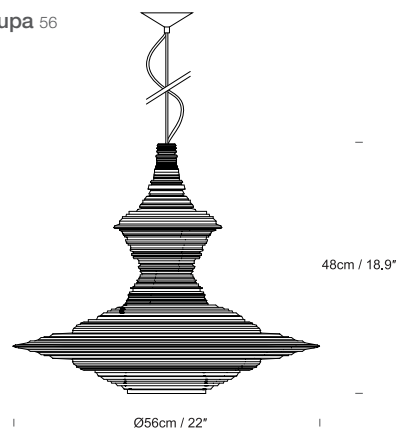



Darc Awards, London, UK

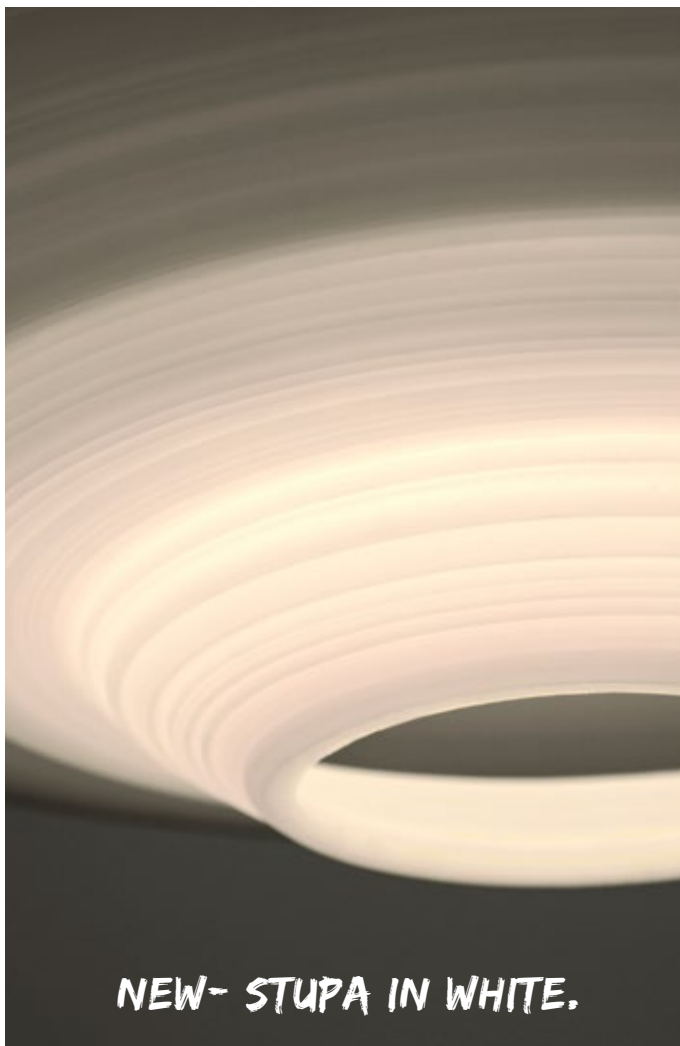

NEW- STUPA IN WHITE.



Facet 100



Facet BY TOM KIRK



Facet 18

London Square Star & Garter, Richmond Hill, England
 Designer: Suna Interior Design
 Photographer: Matt Livey

Material: Stainless Steel, Brass

Polished Stainless Steel-03
 Brass-30

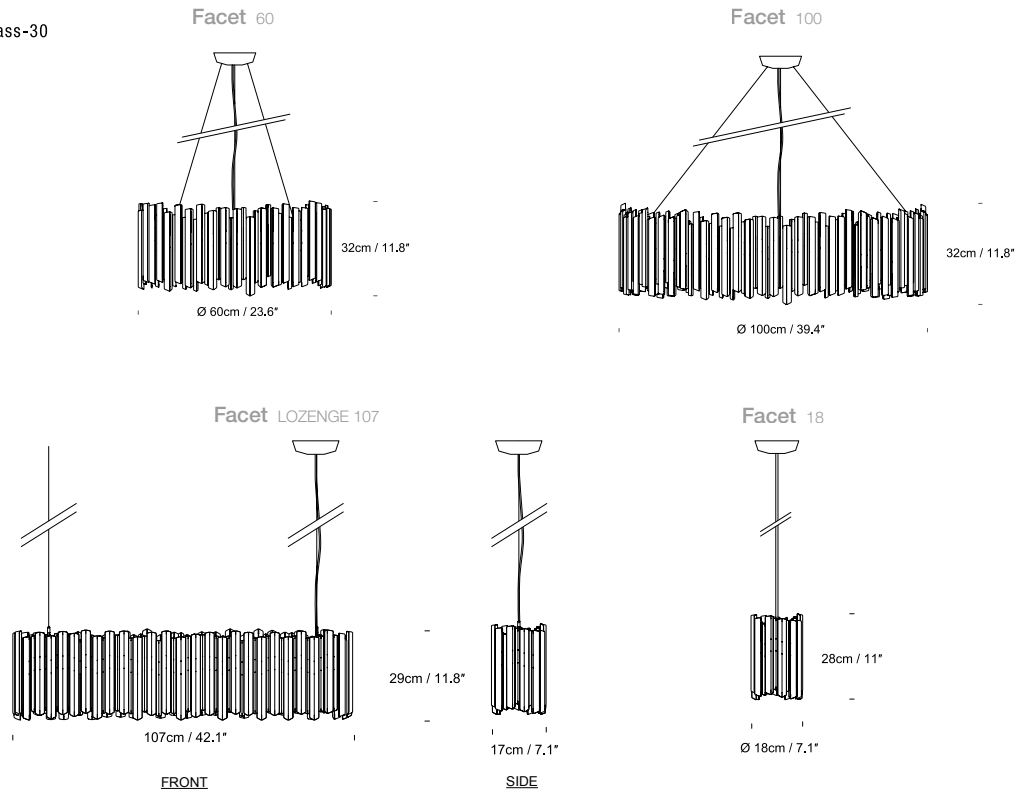



Dooley's Lidcombe Catholic Club, Sydney, Australia



Hotel Xenia, London, England



Furla Flagship Retail Store, London, England
 Designer: HMKM
 Photographer: Marcus Peel

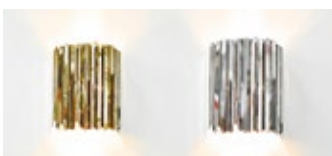

See P.82 for the matching wall lamp



Facet LOZENGE 107



Polished stainless steel sections arrayed around its circumference create a surface of small facets, each helping to present part of an amazing fragmented image of its surroundings. The effect often fools the eye into thinking you are looking at glass or crystal until you get closer.



Beads OCTO



Beads PENTA

Beads

BY WINNIE LUI





Material: Stainless Steel & Polycarbonate



White-01



Chrome-03



Copper-07



Gunmetal-31

Beads PENTA

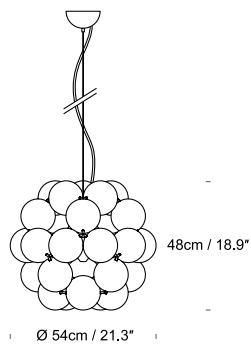

Beads OCTO

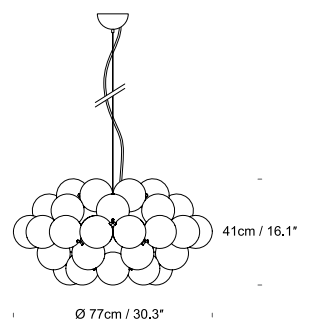

Download "Quikkly" and watch the video on Youtube now!



Akyra Manor Hotel, Chiang Mai, Thailand



Beads brings together the best detailing and finishing from designer Winnie Lui's jewellery craft and blends it with the engineering and technology of modern lighting design.

The results are these striking forms which when lit provide an array of infinite reflections, as if the interior was inlaid with jewels.

Rose Ave, United States
Design Firm: PSMODern
Designers / Principals: David Weiss and Manuel Frausto
Photographer: Lance Gerber, Nuvue Interactive, LLC



Residence, Hong Kong

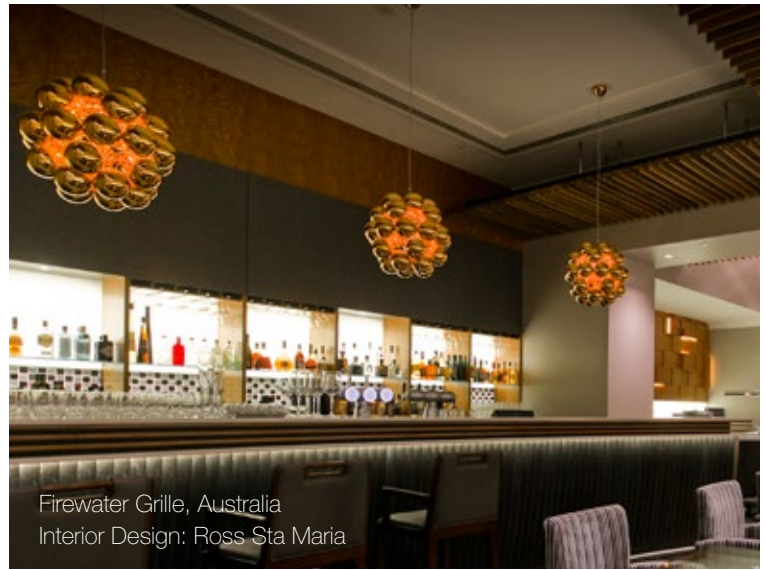

Firewater Grille, Australia
Interior Design: Ross Sta Maria



Kensington 2, United Kingdom
Project: Private Residence
Designer: Morph Interior



M/S Viking Grace, Finland

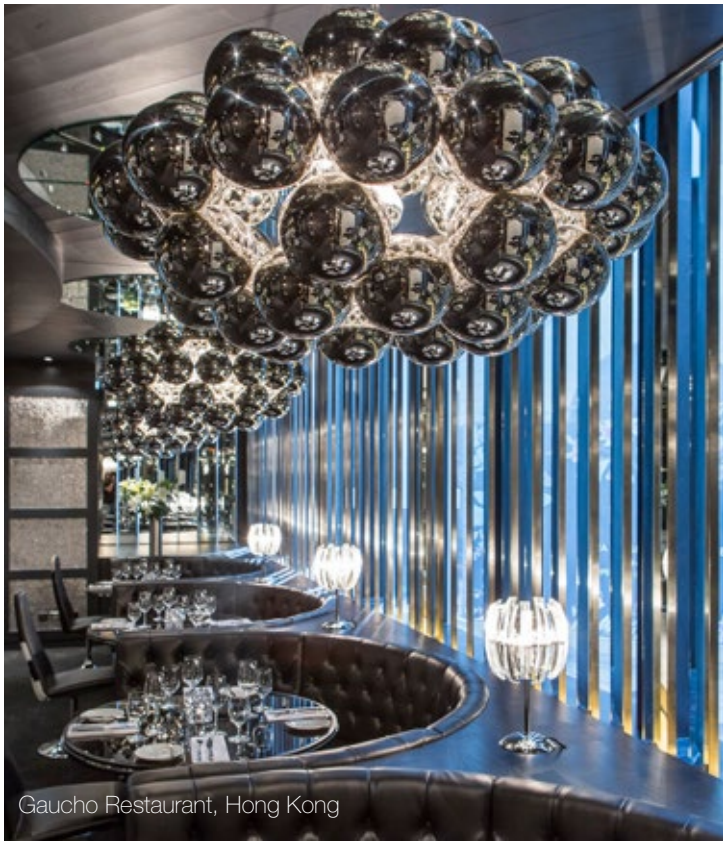

Gauchos Restaurant, Hong Kong



PKS Philosophy of Kudos + Style, Cyprus



Axcel E'Lever Hair Salon, Japan
Design: Roots of Style





Membrane

BY JETTE SCHEIB

Membrane's smoky hand-blown glass body seems to cool and harden at the precise moment bulb and shade become one, forever encapsulating light sources.

Details such as a gentle gradient in smoky glass coupled with polished gunmetal fittings result in a sophisticated design well suited to upscale interiors.





Download "Quikkly" and watch the video on Youtube now!

Material: Glass & Aluminium

Membrane

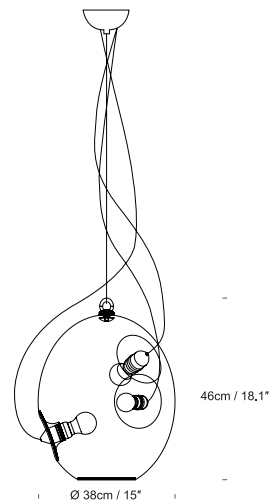



Bubble

BY STEVE JONES

Where the removal of one ball is a welcome change!



CAU Restaurant – St Katherine Docks, London, England
Creative Director: Patsy Godik



Metro Department Store, Singapore
Designer: Metro in-house consultant
Photographer: Beng Chye from Studio Friend



Material: Steel



White-01



Black-02



Chrome-03



Copper-07



Black & Copper-62

Bubble

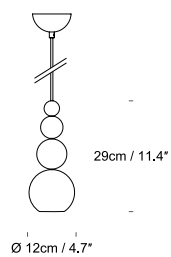



Hei House, Wanchai, Hong Kong
Design: Regal Power Holdings
Photography by VG Media



Yo! Sushi Chelmsford, England
Designer: Philip Watts Design



Buckle

BY TINA LEUNG

Material: Mirror polished stainless steel & white powder coat

Buckle 70

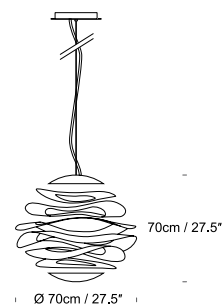

Buckle 120

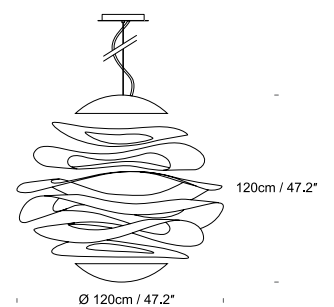





Buckle is an ambient lighting sculpture – it illuminates by bouncing light off its own internal surfaces and provides background light.

It is neither a classic up or downlighter but produces a unique effect all of its own. The effect it creates has often been likened to light bouncing off water.



Platinum Blow Dry Bar, Australia
Designer: Forward Thinking Design



No.1 Traveller Lounge, London Heathrow Airport
Designer: Inside Out Architecture



Country Gardens Showroom, Singapore



Matrioshka

BY STONE DESIGNS

The Russian nesting doll is here reimagined in layers of hand-blown glass. Light passes through each pigmented glass filter to create a magical chromatic effect as colours converge to form new ones.



Material: Glass



Grey-05



Red-08



Blue-12



Yellow-27

Matrioshka

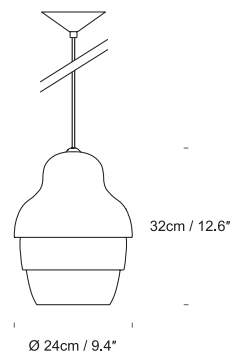









Snowdrop

BY STONE DESIGNS

A soft glow playfully peeks through candy-coloured veils.
Each Snowdrop drifts effortlessly in mid-air,
delivering charm and character to any room.

Material: Aluminium & Glass

	Purple-09		Pink-14
	Orange-11		Yellow-27
	Green-13		Aqua-28

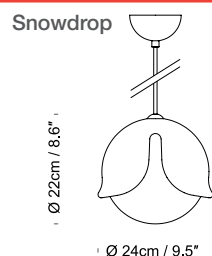

Yo! Sushi Birmingham, Grand Central Birmingham, England



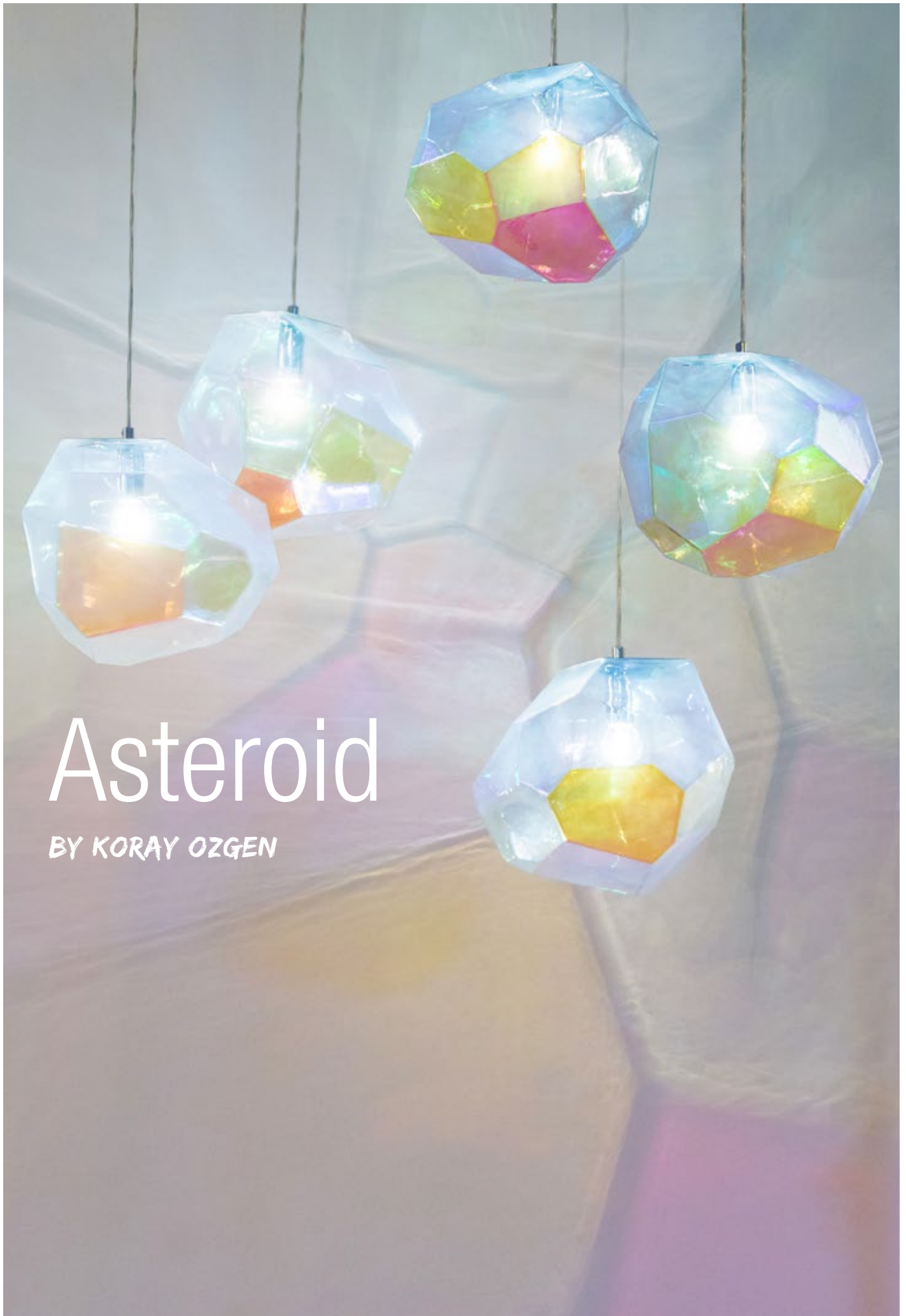

Asteroid

BY KORAY OZGEN



Asteroid is a unique geometrical form in which no two of its twenty-four individual faces are identical and no two edge lengths equal. In clusters, this creates the illusion of many different shapes, when there is only one.



**Asteroid is also available as a table lamp.
See P.90 for more details.**



Maze Restaurant, Portugal

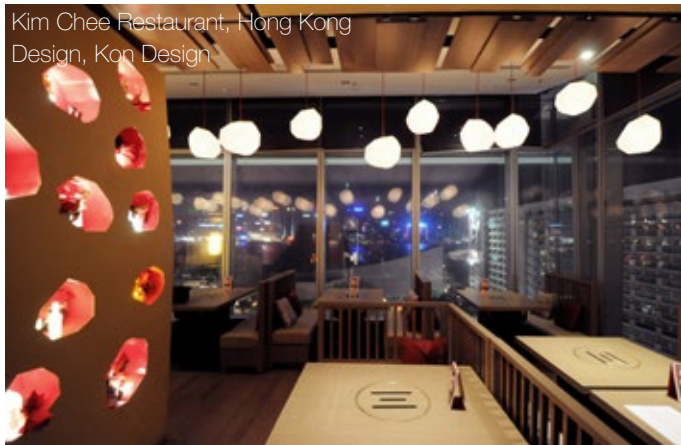

Kim Chee Restaurant, Hong Kong
Design, Kon Design



Topaz Restaurant, Istanbul
Design, Ozgen Design Studio

Material: LDPE Plastic or Glass



Asteroid PENDANT PLASTIC

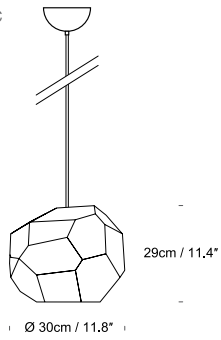

Asteroid PENDANT GLASS

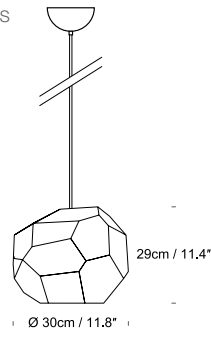



Gable BY JARROD LIM

Jarrold Lim literally puts a roof over our heads with the iconic shape of Gable. Simultaneously playful and functional it hides a technically advanced interior.

Material: Aluminium & Polycarbonate



Gable

UK/EU

SIDE

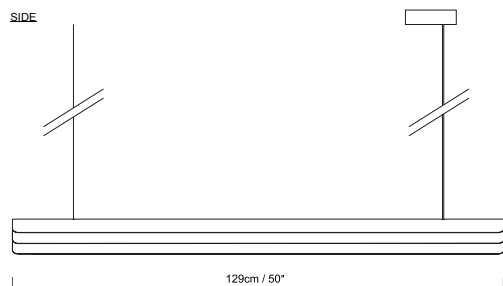

END

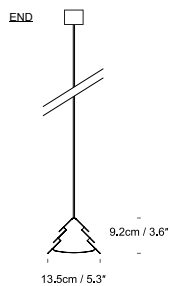

USA

SIDE

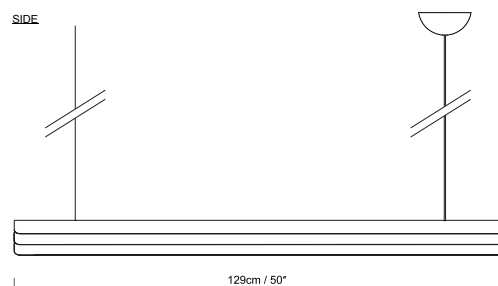

END

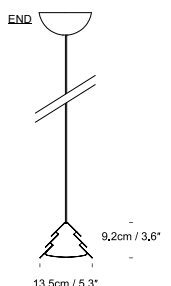





Latitude BY FLYNN TALBOT

Flynn Talbot puts the average spotlight back in the spotlight as he transforms it into a centre piece rather than mere support lighting. A clever suspension cable allows the light to be pointed in any direction, creating a flexible light that activates the surrounding space.



Sodexo Office, Singapore
 Designer: M Moser



Material: Aluminium & Steel

- White-01
- Black-02
- Red-08

Latitude

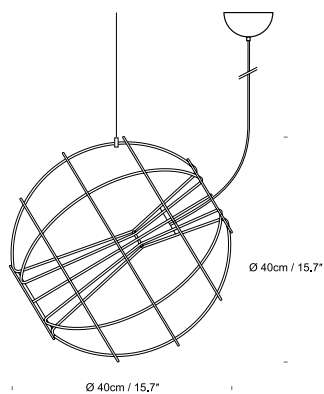

Download "Quikky" and watch the video on Youtube now!

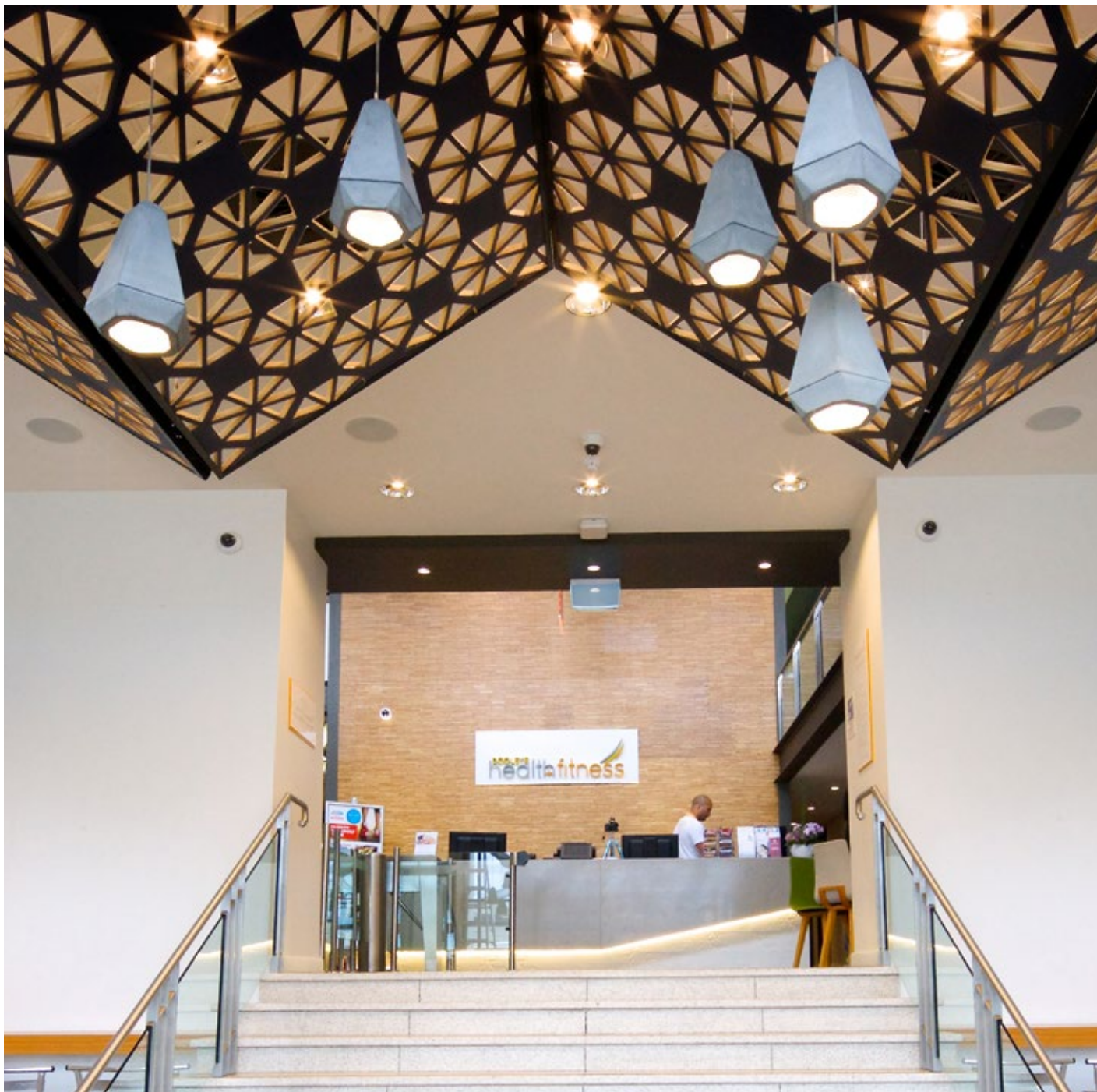

Dooley's Lidcombe Catholic Club, Sydney, Australia

Portland

BY JAMES BARTLETT

Material: Natural Concrete and Coloured Interior

Material: Plaster

- White-01
- Red-08
- Aqua-28

Portland 19

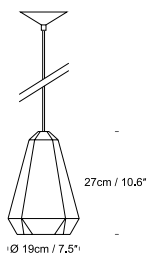

Portland 37

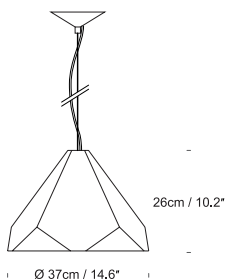

- White-01

Portland 19

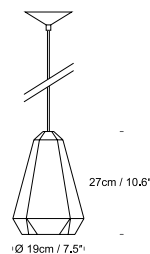





Kensington 2, England
Designer: Morph Interior



Plaza Premium Lounge, London Heathrow Airport Terminal 4, England

Portland,

a design offered in two commonly used construction materials:
the rough cast of concrete and the milky smooth purity of plaster.

Concrete comes with three interior colour options:
aqua, red or white; and the plaster is pure white with nothing added.

Its pentagonal jewel-like shape is designed to
work well in clusters, patterns or lines.

A cool, calm, detailed addition
to even the most minimally designed interior.



La Chemise, Germany
Design Studio: saczi Design
Interior & Product Design:
Sarah-Rebecca Zimmer (Dipl. Des. Industrial Design)



Jeeves & Wooster

BY JAKE PHIPPS

Jeeves and Wooster are a blend of Great British tradition and modern technology- hand made wool felt hats lined with an aluminium inner shell. They are named after P.G. Wodehouse's two iconic characters: Wooster, the jovial but empty-headed young gentleman, and Jeeves, his improbably well-informed and talented valet.

Material: Aluminium & Wool felt

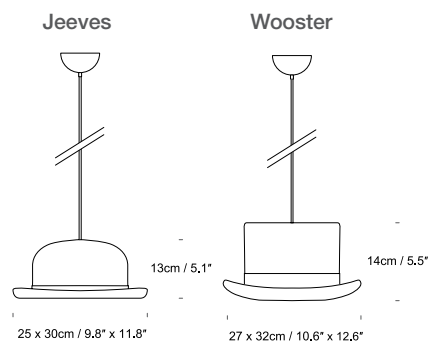

Jeeves is also available as a wall and a table lamp. See P.84 & P.96 for more details.



La Suite, Belgium

Designer:

Henk Van Oudenhove & Veronique Bogaert (Sans Cravate)

Photographer: Piet De Kersgieter



Dar Kawa, Morocco
 Designer: Valérie Barkowski
 Photographer: Tania Panova



Le Bon Marché, Paris



Burton of London, Paris



Ritz Carlton, Bahrain
Design: Ammar Basheir



C3RV34U Exhibition, Paris Science Museum



Cafe The Loft, Greece



Hotel Portago Urban, Spain
Designer: ILMIODESIGN (Andrea Spada, Michele Corbani)
Photographer: Alfonso Acedo

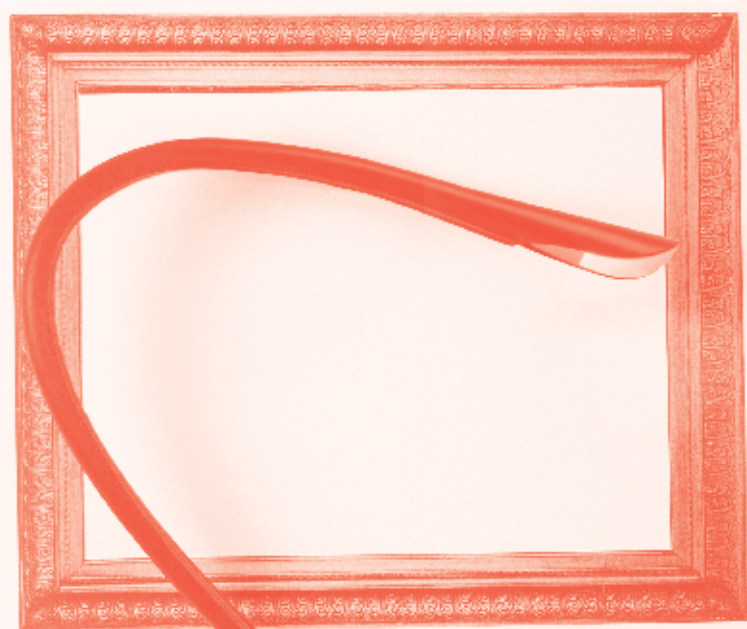

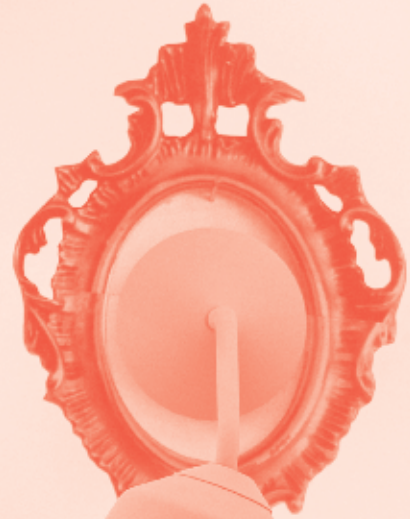

WALL LAMP



Cobra BY INNERMOST

- Wall mounted task lighting
- Adjustable neck
- Natural leather finish
- Touch activated switch
- USB port charging station

Material: Steel, Aluminium, Leather



White-01



Brown-10

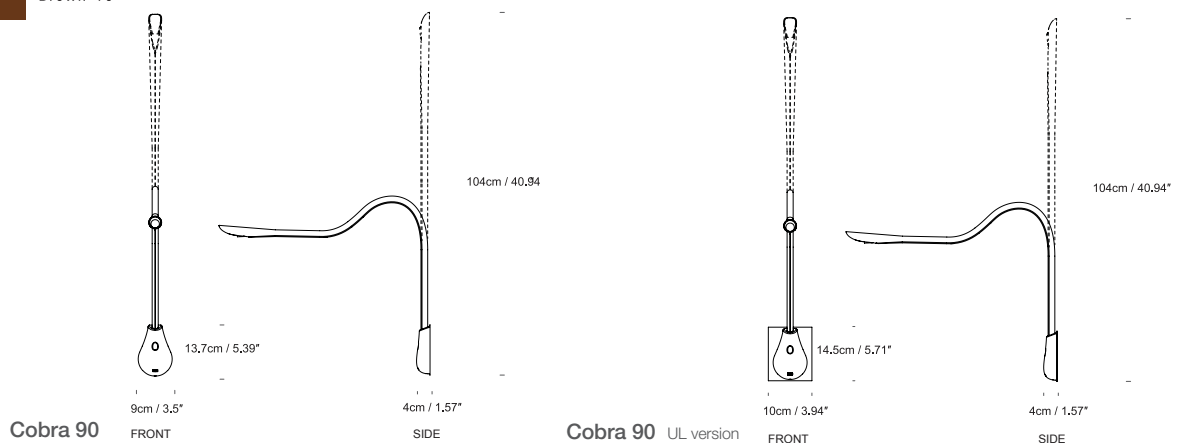



Download "Quikkly" and watch the video on Youtube now!



Circus Wall

BY CORINNA WARM

Simple and elegant LED wall sconces based on Victorian Circus tents.



Material: Aluminium

-  White with Antique Gold Interior-01
-  Black with Antique Gold Interior-02
-  Grey with Matt White Interior-04



Ø 15cm / 5.9"

FRONT

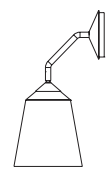

19cm / 7.5"

35cm / 13.8"

SIDE



See P.18 for the matching pendant



Bolt

BY STEVE JONES

A building's history weighs heavily on each nut and bolt. Reclaim that industrial detail in a contemporary space with this dimmable LED wall sconce.

Material: Aluminium

Bolt

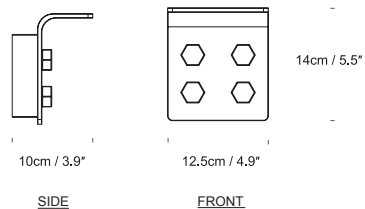



Bracket BY STEVE JONES

A minimal slim section wall fitting based on the overall dimensions of our Bolt fitting.

Material: Aluminium

Bracket

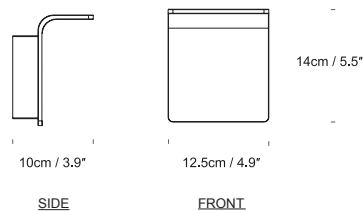



YOYWall BY YOY

Following our successful collaboration with YOY on the popular YOYLight — a table lamp that projects its own virtual lampshade, we present you YOYWall. YOYWall is arguably the most minimal wall sconce possible, interacting with and using the wall in more than just a supporting role.



Material: Aluminium & Steel

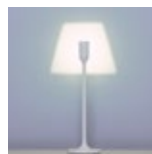
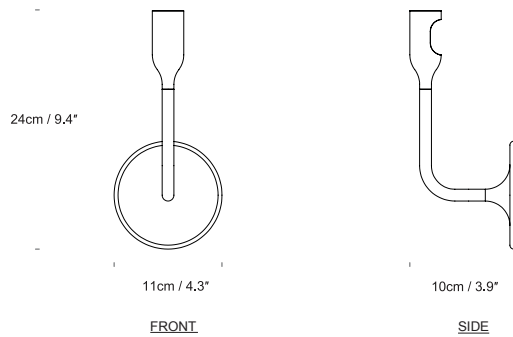

See P.94 for the matching table lamp.



Facet Wall BY TOM KIRK

Material: Stainless Steel, Brass

Facet WALL

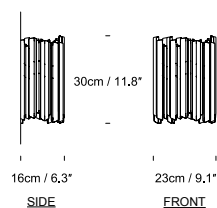

Go to P.30 for the matching chandelier and pendant collection



Lighthouse Wall

BY INNERMOST

Material: Polycarbonate

Lighthouse WALL

SIDE FRONT
12cm / 4.7" 28cm / 11"

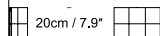
 20cm / 7.9"



See P.106 for the matching lampshade collection

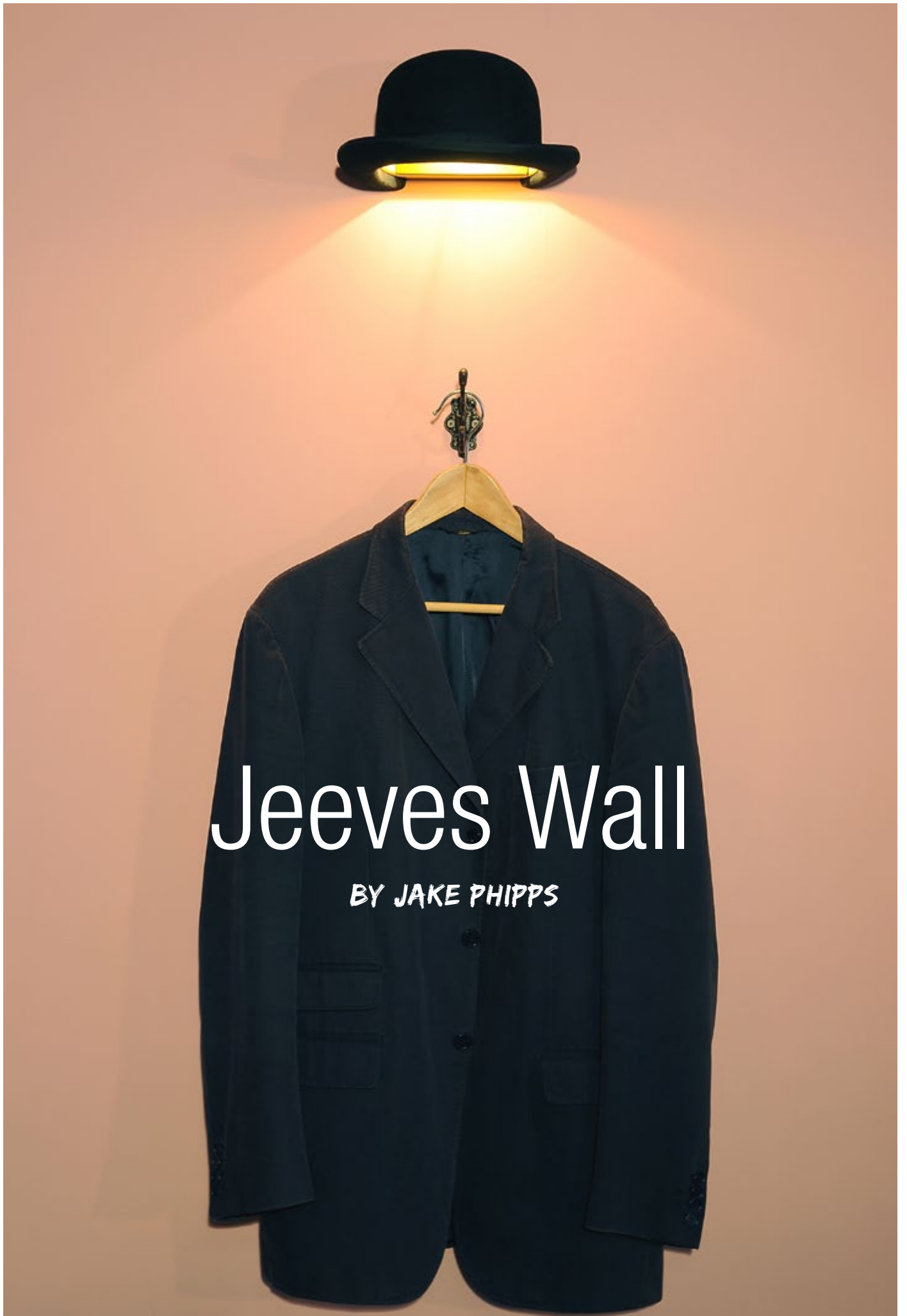

Jeeves Wall

BY JAKE PHIPPS



The Bowler Bar, Belgium



The Builder's Arms, London

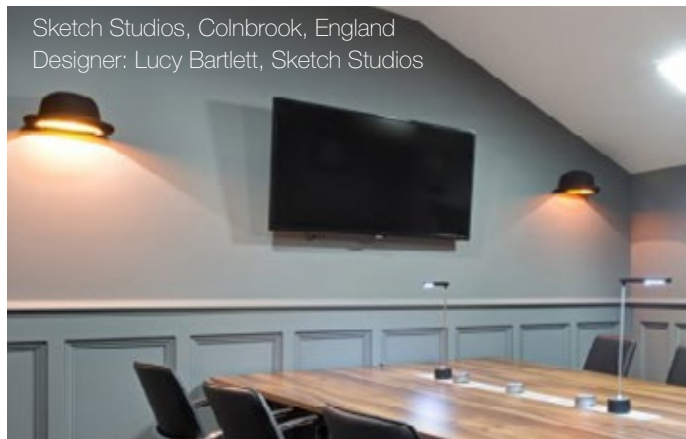

Sketch Studios, Colnbrook, England
Designer: Lucy Bartlett, Sketch Studios

Material: Aluminium & Wool felt

Jeeves WALL

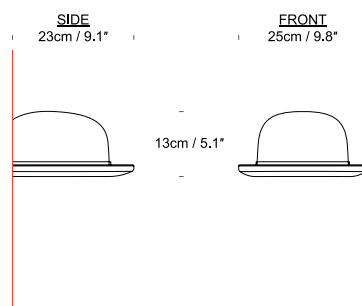

P.68

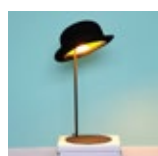

P.96

Jeeves is also available as a pendant and a table lamp.





TABLE & FLOOR





GERMAN
DESIGN
AWARD
SPECIAL
2016



Lateralis

BY BEN MCCARTHY

Artisan crafted glass seems to pour upwards and outwards following the breath of the glass blowing artist, producing a honey-coloured dome with a similar syrupy consistency. It collects in a pool of dark timber below. At the heart of the table light, dark ripples of wood reflect off of polished brass.

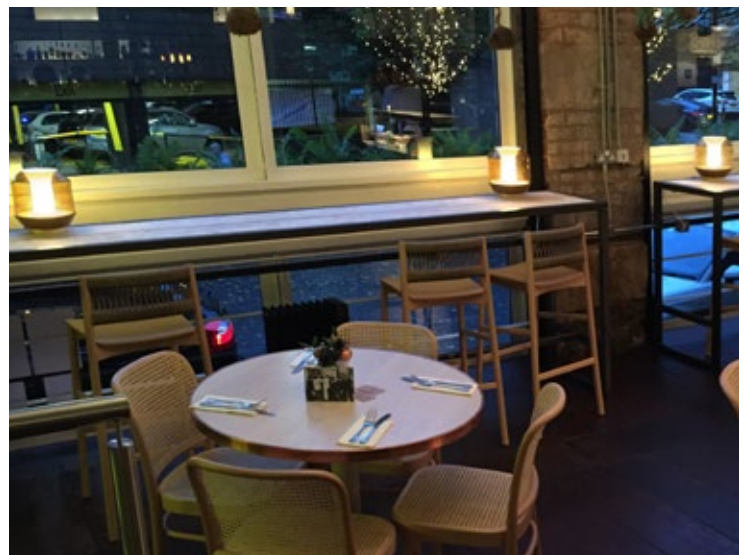
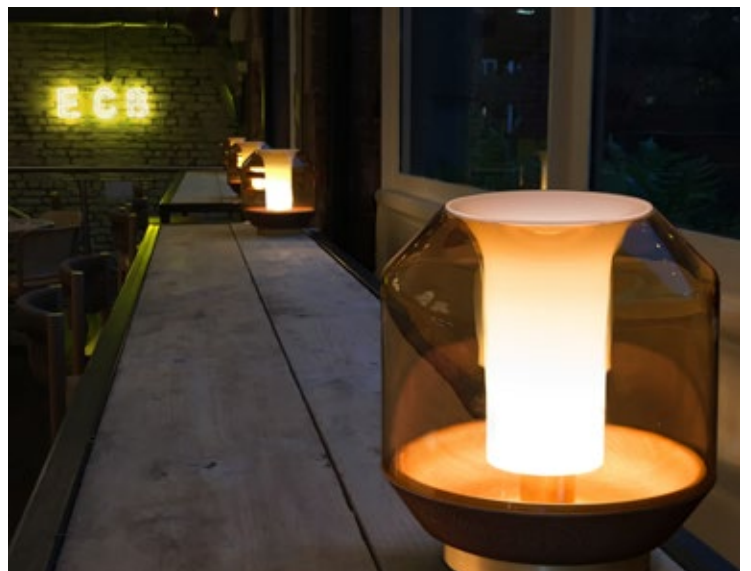

Material: Glass, Dark stained ash wood, Anodised Aluminium

Lateralis

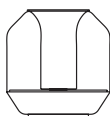

25cm / 9.8"

Ø 23cm / 9.4"

Evelyn's Cafe Bar, Manchester, England

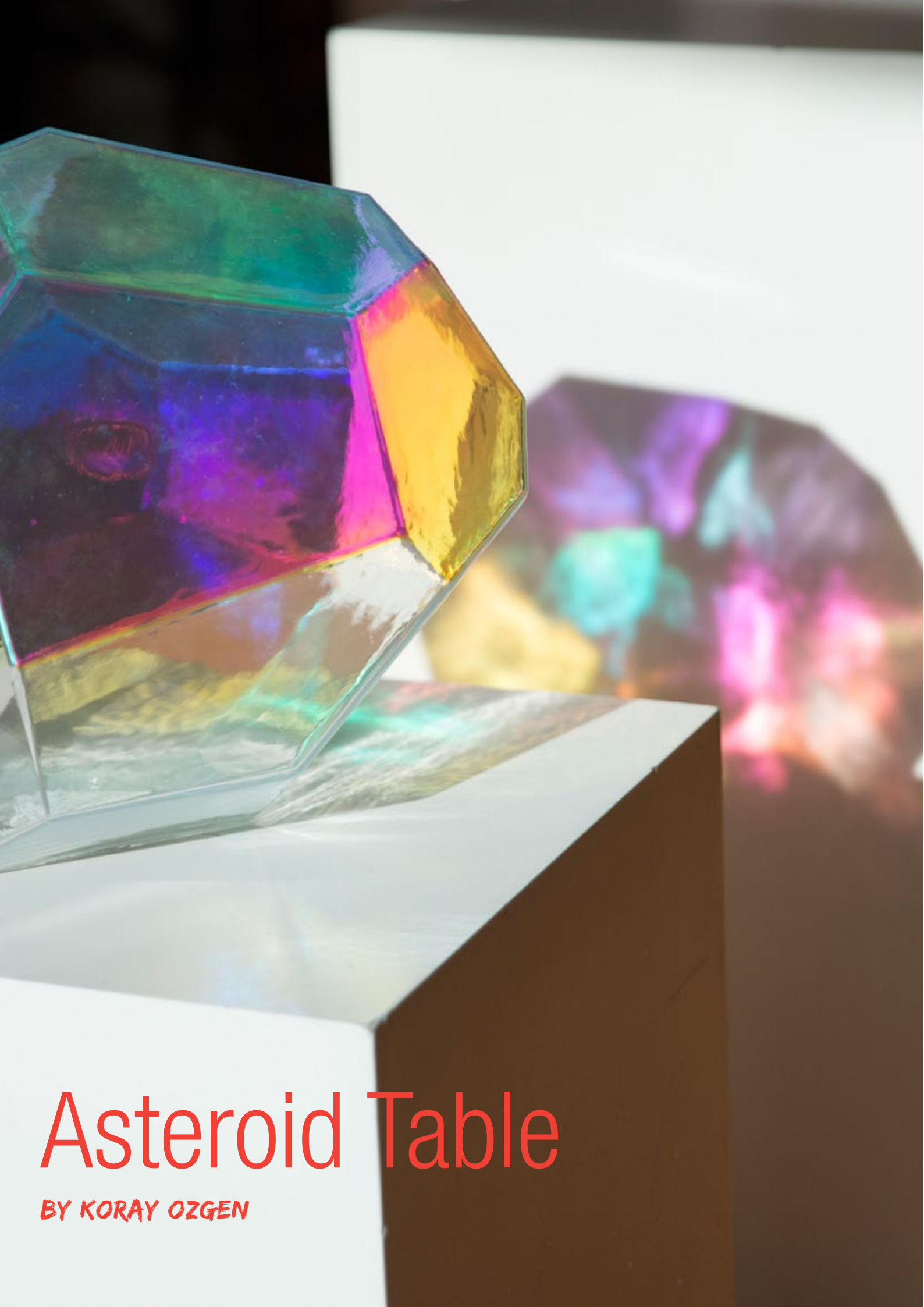

Asteroid Table

BY KORAY OZGEN



Material: LDPE Plastic or Glass

Asteroid TABLE PLASTIC

Asteroid TABLE GLASS

Ø 30cm / 11,8"

Ø 30cm / 11,8"



29cm / 11,4"



29cm / 11,4"

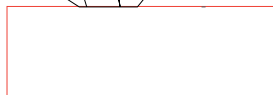

See the matching pendants on P.56

Parasol

BY JONAS FORSMAN





Soft, gentle reflected light is cradled in a very literal parasol in Jonas Forsman's simple design. Free movement of the shade gently guides the light to its intended use. Forsman's design focuses on the interaction between user and product, aiming to delight through refined and balanced movements.

Material: Steel



Parasol

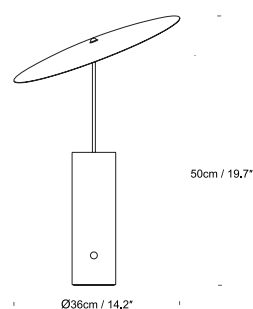



YOYLight BY YOY

Ever defiant of the laws of our reality, YOY presents an LED lamp that projects an illusion of a classic lamp shade onto the wall. A perfect marriage of illusion and technology.

Material: Steel & Aluminium



See P.80 for the matching wall lamp

YOYLight

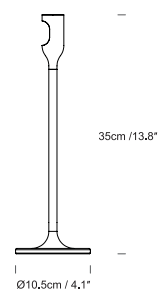



Jeeves Table

BY JAKE PHIPPS





Material: Aluminium & Wool felt

Jeeves TABLE

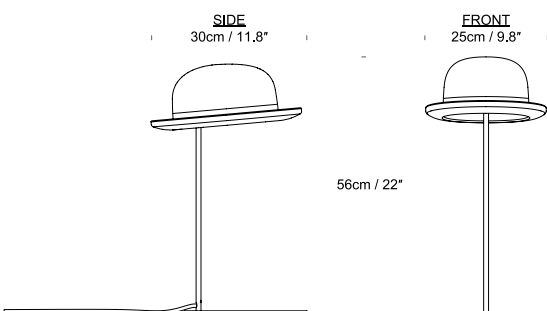

P.68

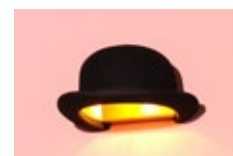

P.84

Jeeves is also available as a pendant and a wall lamp



RD2SQ

BY STEVE JONES



Material: Steel, Acrylic, Polyester

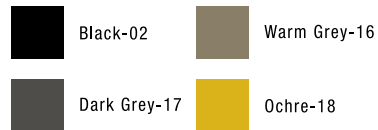

RD2SQ TABLE

*unit includes base and shade, choices of base:

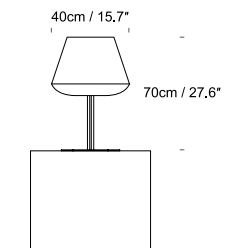

RD2SQ FLOOR

*unit includes base and shade, choices of base:



See the matching lampshades on P.116





LAMP SHADES, BASES & FITTINGS





Standing between art and function, Bowness' designs break away from traditional wallpaper patterns and colours into trompe l'oeil images that appear to interact with the objects in the three-dimensional space.



P.131



P.132

Perfect with the Trumpet or Tripod bases.



Moscow Graffiti

BY DEBORAH BOWNESS

As its name implies, Moscow Graffiti was inspired by designer Deborah Bowness' travels in Russia. With a keen eye, constantly observing the surfaces which surround us, Bowness aims to bring exterior surfaces into the home.

Material: Steel, Acrylic, Polyester

*supplied as shade only

Moscow Graffit 46

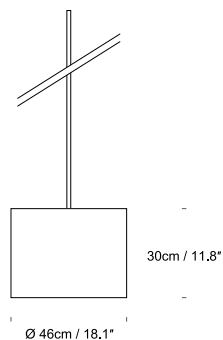

Moscow Graffit 60

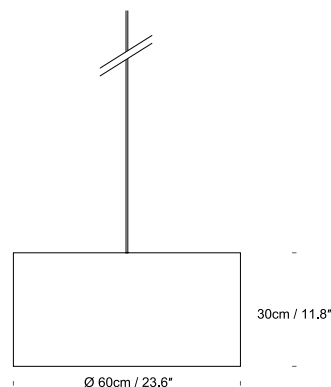



Bric-a-Brac

BY DEBORAH BOWNESS

Using images taken from the shelves of a French farm house in Brittany, Bric-a-Brac creates the illusion of a shelf of objects where there is none.

It's a cabinet of curiosities, without the hassle of one.

Material: Steel, Acrylic, Polyester

*supplied as shade only

Bric-a-brac 46

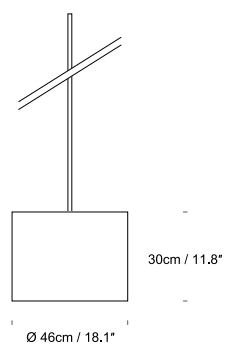

Bric-a-brac 60

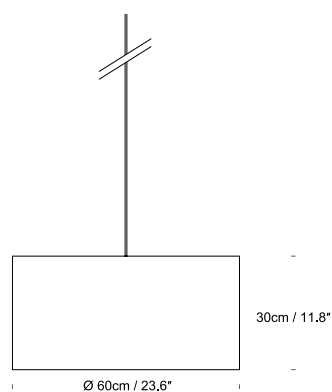



Laurie Grove

BY DEBORAH BOWNESS

Unapologetically bold, Laurie Grove captures the familiar interior details of an Old London Pub.

Material: Steel, Acrylic, Polyester

*supplied as shade only

Laurie Grove 46

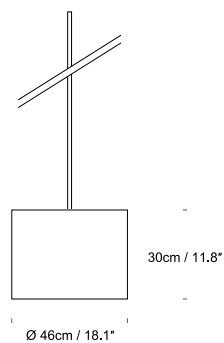

Laurie Grove 60

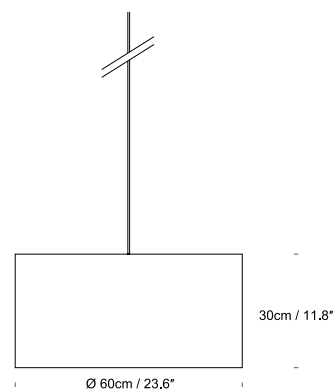



Lighthouse

BY INNERMOST



See P.83 for the matching wall lamp.



P.131



P.132

Perfect with the Trumpet or Tripod bases.



Lighthouse 60*40

Take one light bulb and multiply.
An array of lenses help create this stunning optical effect as the light source is duplicated.



Material: Polycarbonate

*supplied as shade only

Lighthouse 30*30

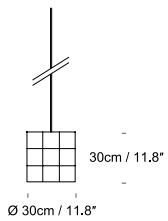

Lighthouse 46*30

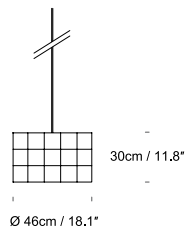

Lighthouse 60*30

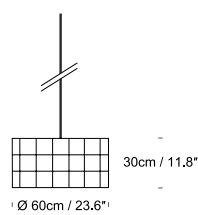

Lighthouse 60*40

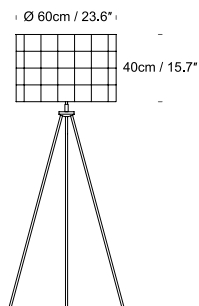

Lighthouse 30*20

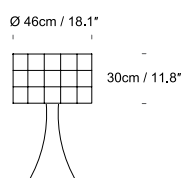
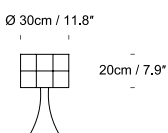

Lighthouse 30*30
with trumpet base 35







Arkada House Apartments, Cyprus
Design and Photography: PKS Philosophy of Kudos + Style



Lighthouse 46*30
with Trumpet base 50

Dent

BY CHAK



Balthasar Kaffee Bar, Vienna, Austria
 Design: Eugenie Art, Loesungsraeume Interior Design



Contemporary and uncompromising; the ultimate shiny polished metal shade. Was it hit by a hammer or dropped in the factory; did bullets bounce off it during testing? None of that.

Clever trickery from Chak makes Dent look like it's pressed or blown metal; when in fact it's not! In reality it's soft and lightweight and comes flat packed. It takes 30 seconds to put together with no tools and very few brain cells!

Material: Polyethylene, Synthetic Wadding



*supplied as shade only

Dent 53

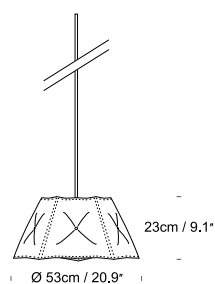

Dent 80

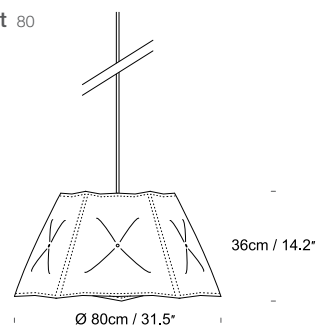

Kapow!

BY TINA LEUNG



A playful use of a simple material makes something that is witty and charming but never obtrusive. Great when used alone and stunning when grouped closely together to create a bigger piece.



Material: Woven Nylon Tubing

Kapow!

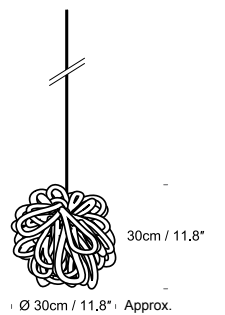

Ø 30cm / 11.8" Approx.

*supplied as shade only

RD2SQ

BY STEVE JONES



Coll Blanc Restaurant, Andorra
Designer: Stone Designs

A subtle change in shape from square at the base to a circle at the top, combined with a molded diffuser to complete a simple but distinctive design.



Material: Steel, Acrylic, Polyester

*supplied as shade only

-  Black-02
-  Warm Grey-16
-  Dark Grey-17
-  Ochre-18

RD2SQ SHORT 40

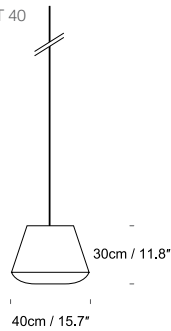

RD2SQ 60

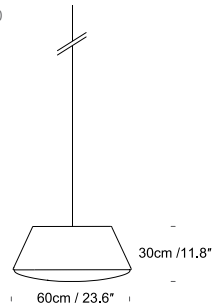

RD2SQ TALL 40

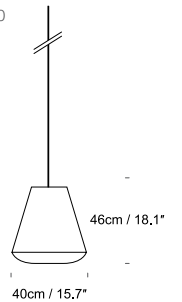

See the matching table and floor lamps on P.98



MnM

BY STEVE JONES

Love Coffee, Westfield London, England



When asked to describe his design, Steve Jones replied;

***'it's a normal lampshade
but squashed into a sausage shape and twisted-
but don't print that in the brochure,
make it sound cooler'***

Aloft Downtown Tampa Hotel
Interior Design: Delphine Buhro & Michael Dreher

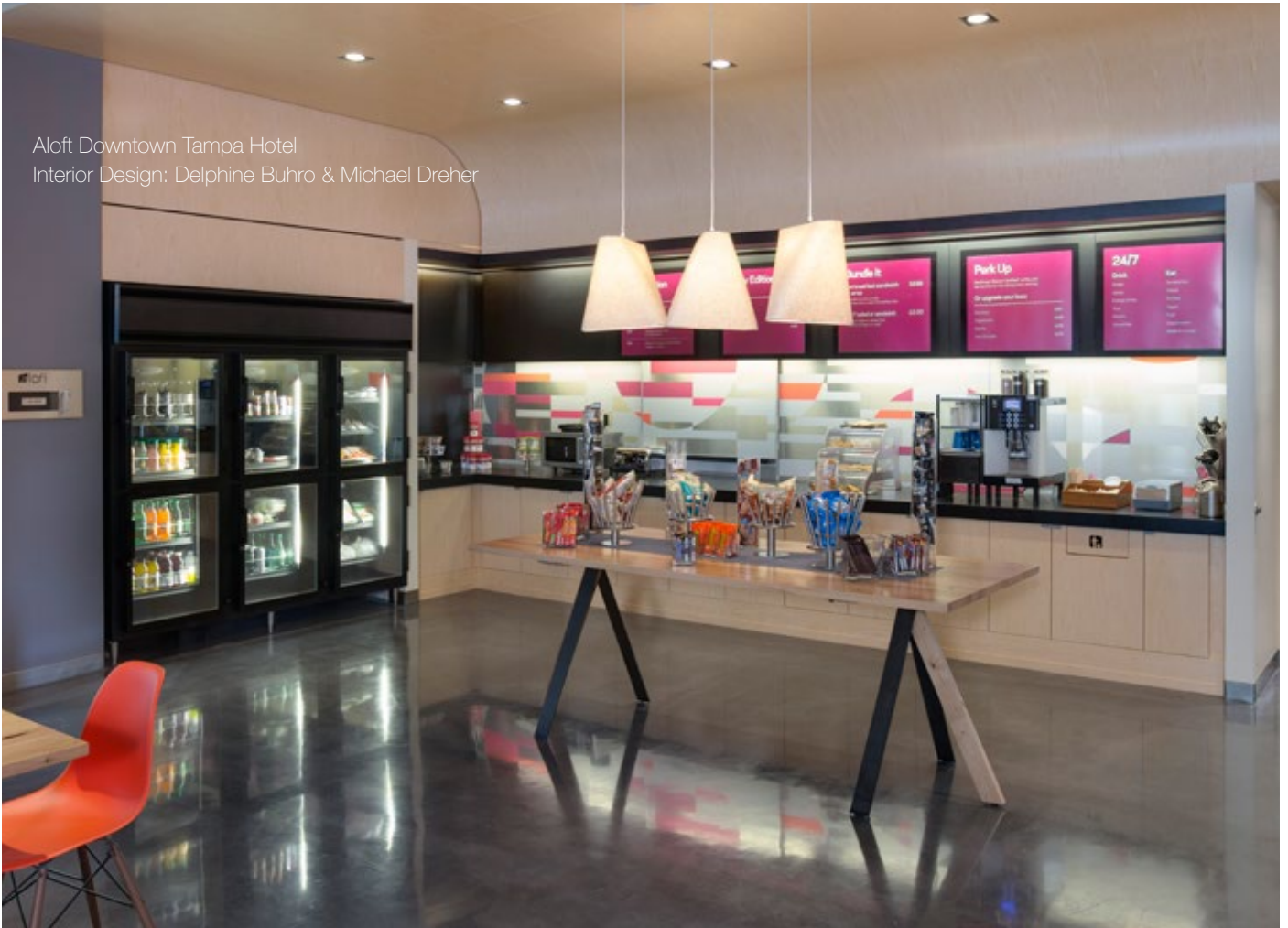

Love Coffee, London, England





25 Hours Hotel, Germany
Interior Design: Delphine Buhro & Michael Dreher



Mascotte Shoe retail shop, Australia
Design: studioplus* group

Material: PVC & 100% Wool

*supplied as shade only

- Charcoal-05
- Natural-06
- Red-08
- Purple-09

MnM 40

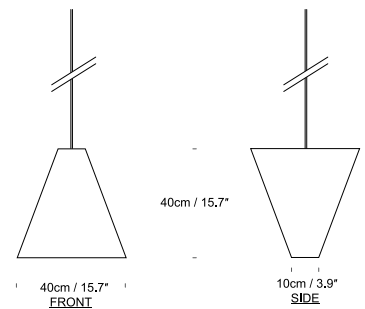

MnM 60

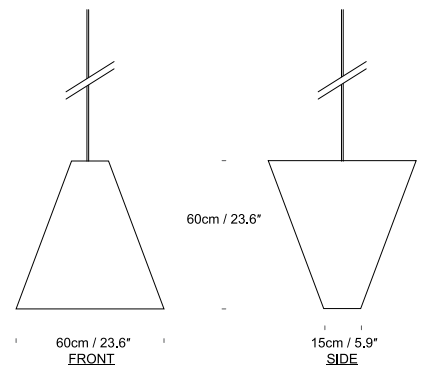



Cork BY INNERMOST

Natural cork served wafer thin to allow delicious light to filter through.

Material: Natural Cork backed onto PVC, Powder coated Steel



Smoke-05

Cork 20*40

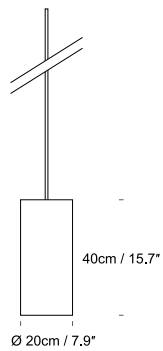

Natural-06

Cork 46*30

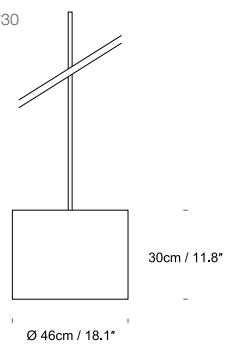

*supplied as shade only



P.131



P.132

Perfect with the Trumpet or Tripod bases.



Cork 46*30



Cork 20*40

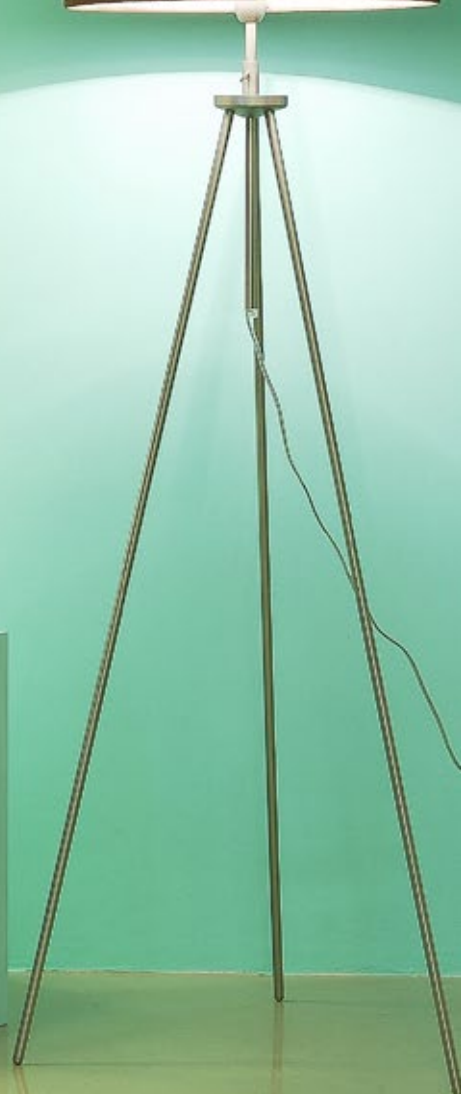



Kobe 32*26



Kobe 60*30



Kobe

BY RUSSELL CAMERON

A collection of simple drum shades in high quality materials for that sophisticated feel. Kobe comes flat-packed with an edge to edge diffuser and assembles in seconds.



P.131



P.132

Perfect with the Trumpet or Tripod bases.



Kobe 32*26

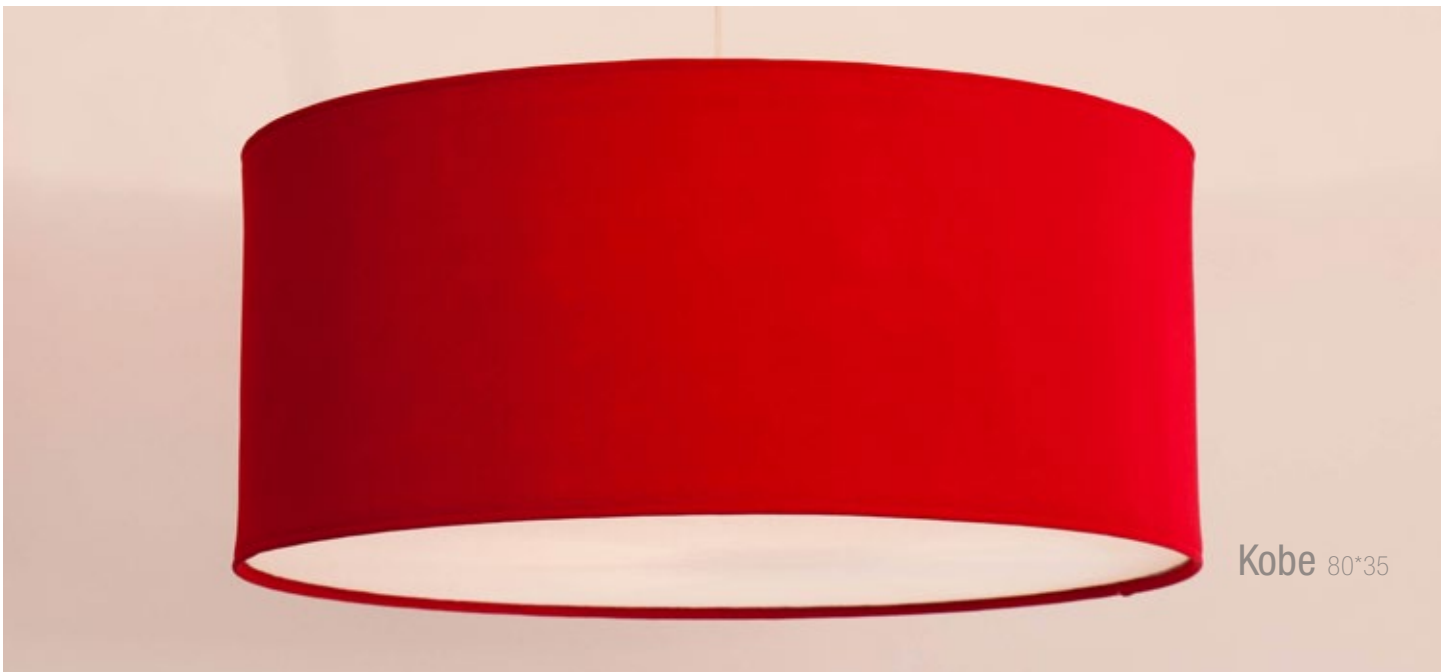

Kobe 80*35

Material: Polyester/ 100% Wool

Polyester:

- Black-02
- Warm Grey-16
- Dark Grey-17
- Ochre-18
- Red-29

Wool:

- Charcoal-05
- Natural-06
- Red-08
- Purple-09

*supplied as shade only

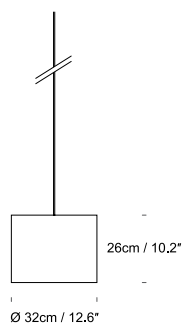

Kobe 32*26

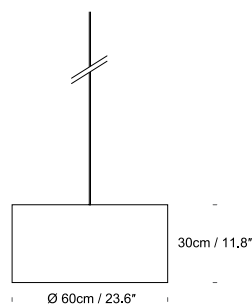

Kobe 60*30

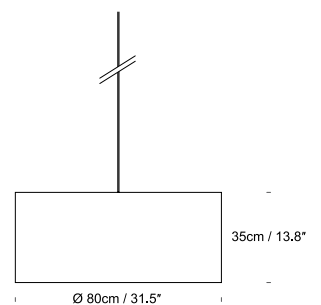

Kobe 80*35





Barclays House Hotel, London (England)
Interior Design & Photography : Geneviève Thériault





Metallic BY INNERMOST

An amazing sparkling reflective surface achieved by using materials usually the preserve of the automotive customisation industry.

Material: Polyester/ 100% Wool

*supplied as shade only

- Orange-11
- Blue-12
- Green-13
- Pink-14

Metallic 33

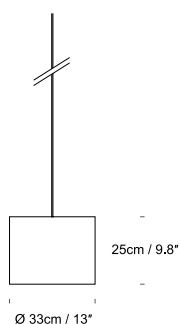

Metallic 60

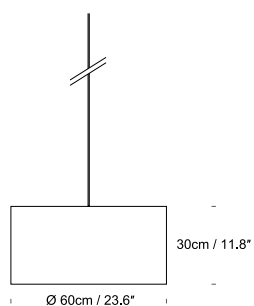



Primark Manchester, England
Project Coordinator: Premier Electrics



Trumpet Base *BY INNERMOST*



Material: Steel

Trumpet Base by innermost



- White-01
- Black-02
- Chrome-03

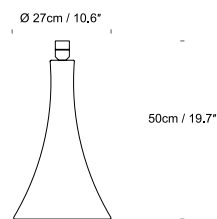

Trumpet Base 50

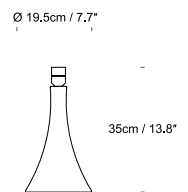

Trumpet Base 35

not available in Black

Tripod Base

BY INNERMOST



Tripod Base by innermost

Material: Steel

SN Satin Nickel- 04

Ø 70cm / 27.6"

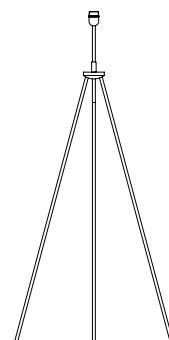

120 - 150cm /
47.2" - 59.1"
* height adjustable

Tripod Base FLOOR

Ø 21cm / 8.3"

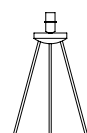

35cm / 13.8"

Tripod Base 35

Pendant Fittings



Pendant Fittings

Material: Steel



White-01



SN Satin Nickel- 04

3CAE27 / 3CAE26

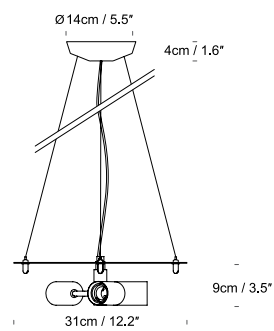

CAE27 / CAE26

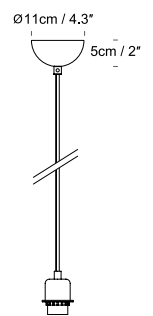

only available
in Satin Nickel





FURNITURE



Origami

BY ANTHONY DICKENS



The Origami table range won a design bursary from Liberty and later the "Elle Decoration Best Table Award" for its ingenious construction - Three identical legs that lock together to form a secure base come flat packed with three hidden screws for the glass top. Assembly is an easy 2 minute job with a small screwdriver.



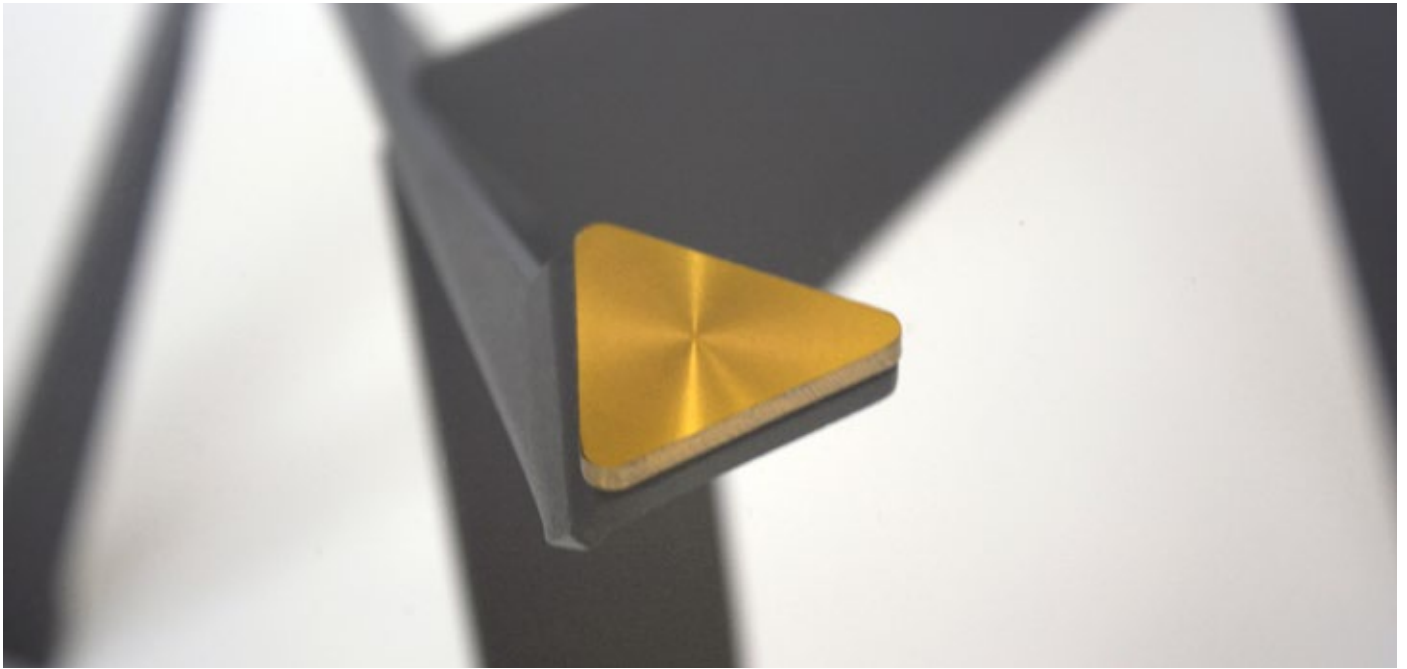

Material: Steel & Glass

- Legs - White- 01
- Black- 02
- Pads - Silver- 04
- Brass- 30

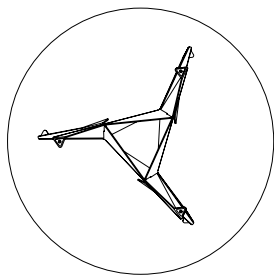

Ø 130cm
51.2"

Origami DINING TABLE 130

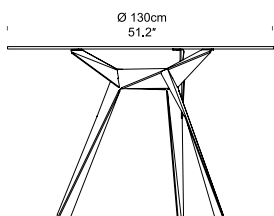

72cm / 28.3"

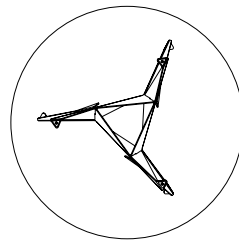

Ø 110 cm
Ø 43.3"

Origami DINING TABLE 110

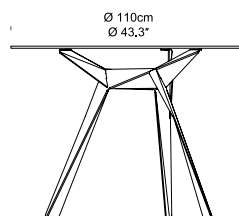

72cm / 28.3"

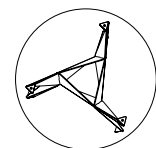

Ø 64cm / 25.2

Origami SIDE TABLE

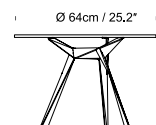

41cm / 16.1"



On/Off London Fashion Week
Innermost Partner: Doll



Private Residence, Hong Kong

Canvas BY YOY

A surreal cartoon feel, where the impossible seems to happen;
lounging effortlessly on a 2 dimensional image leaning against a wall.
A clever construction of structured fabrics hidden within make it possible.
Canvas' cover is removable and machine washable.







Material: Spandex, polyester and wooden frame

Canvas ARMCHAIR

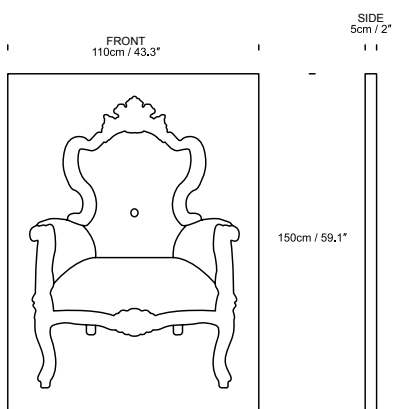

Canvas SOFA

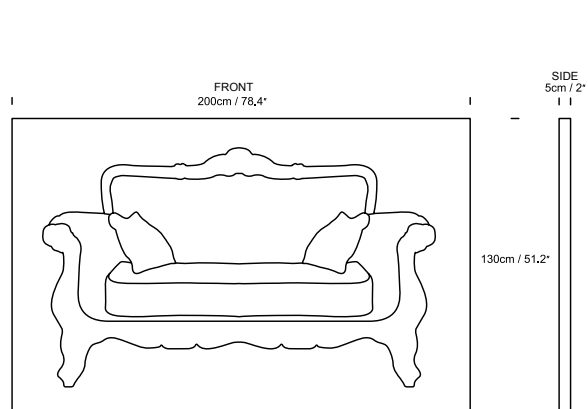



Download "Quikkly" and watch the video on Youtube now!





Exhibition: "Make Yourself Comfortable at Chatsworth", hosted by the Duke & Duchess of Devonshire
Location: Chatsworth House, Derbyshire, England
photograph courtesy of Chatsworth House

Poke Stool

BY KYUHYUNG CHO







Poke Stool is not just another wooden stool-
A series of strategically placed holes not only allow them to stack
and nest together for easy storage,
but also grant them seemingly endless stacking possibilities.

***Poke is a stool for adults
with a spirit of child-like play!***



Material: Wood

Poke Stool

- White- 01
- Black- 02
- Wood- 06
- Red- 08
- Blue- 12
- Green- 13
- Yellow- 27

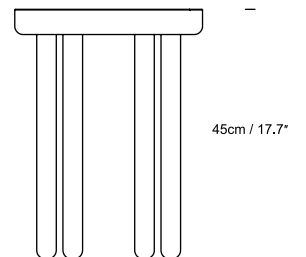
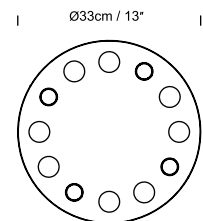

Download "Quikkly" and watch the video on Youtube now!

HiHo

BY JARROD LIM

HiHo is a fun yet stylish take on the traditional children's rocking horse remade for grown-ups. Jarrod Lim designed HiHo so you can sit forward and really ride or alternatively turn around and sit back for a gentler comfortable rocking chair experience. It's practical too and comes with sheepskin covers that are removable for dry cleaning just in case anyone gets too excited.

Our lawyers told us to mention that *'it's not a toy and not suitable for children!'*









Material: Teak Wood & Sheepskin

HiHo

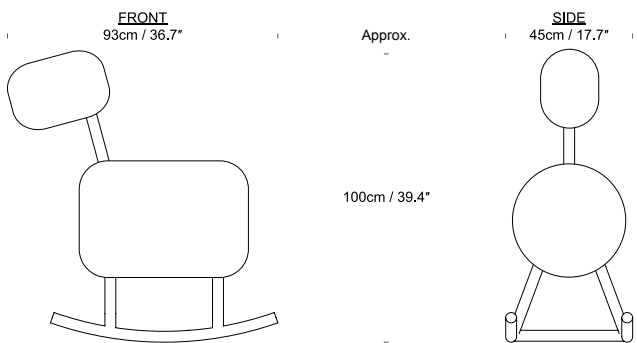

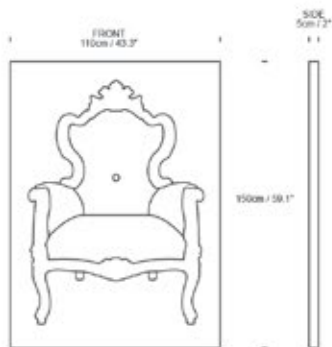
Canvas by YOY**Material** Spandex, polyester and wooden frame

Canvas ARMCHAIR - FC022001

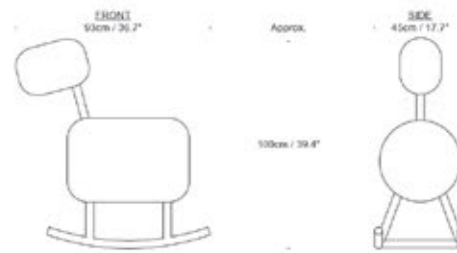
HiHo by Jarrod Lim**Material** Wood & Sheepskin

HiHo - FH011001

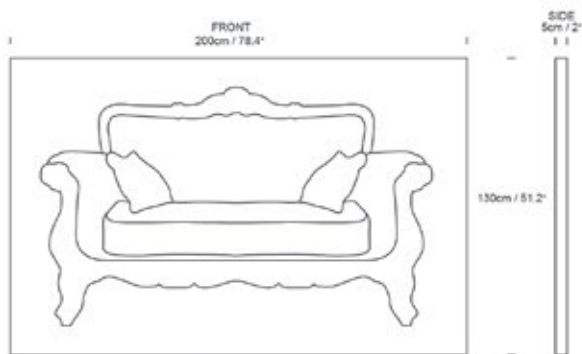

Canvas SOFA - FC023001

Origami by Anthony Dickens

Material Steel & Glass

Legs -  White- 01  Black- 02

Pads -  Silver- 04  Brass- 30

Please specify leg colour code 'XX'.
01-White/ 02-Black
Please specify pad colour code 'YY'.
04-Silver/ 30-Brass

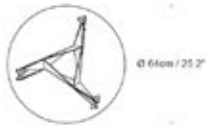

Origami SIDE TABLE | Pads : FO011002YY
Legs : FO011001XX

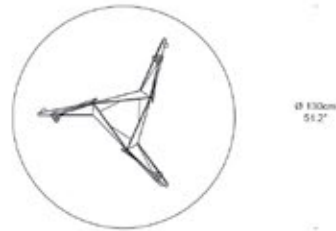

Origami DINING 130 TABLE | Pads:FO013102YY
Legs: FO013001XX

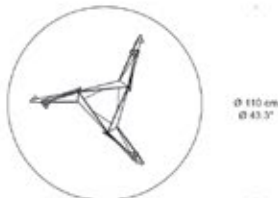

Origami DINING 110 TABLE | Pads:FO013002YY
Legs: FO013001XX

Poke Stool by Kyuhyung Cho

Material Wood



Please specify colour code 'XX'.

01-White/ 02-Black/ 06-Wood/ 08-Red/ 12-Blue/ 13-Green/ 27-Yellow

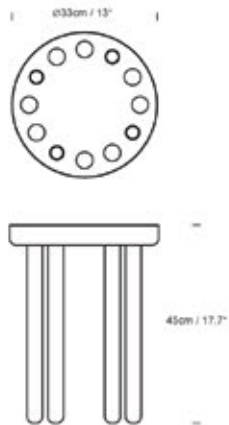

Poke Stool - FP01XX

Asteroid by Koray Ozgen

Product Category Table Lamp/ Pendant
Material LDPE Plastic or Glass



Please specify colour code 'XX'.
00-Clear Glass/ 40-Petrol Glass



Asteroid TABLE PLASTIC WHITE OUTDOOR - UK LA010001
EU LA010301

Lightsource UK/EU E27, Max 60W USA E26, Max 10W
Recommended bulb: Compact LED Bulbs 400 - 1000 Lumen output and from 2700K (for warmer with more colour) up to 6000K (daylight)
Shade aperture measures Ø 5cm / 2"
Cable 4m / 157.5", White Cable
Other details IP44

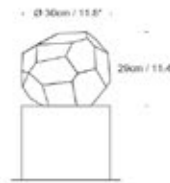

Asteroid TABLE GLASS - UK/EU LA0221XX
USA LA0223XX

Lightsource UK/EU E27, Max 60W USA E26, Max 10W
Recommended bulb: Compact LED filament or soft tone style 2200-2700K with output 300-500 Lumen
Shade aperture measures Ø 7cm / 2.75"
Cable 40cm/ 15.7" to switch, 1.5m/ 59" to plug, Clear cable
Switch inline rocker

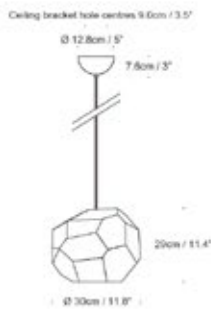

Asteroid PENDANT WHITE PLASTIC - UK/EU PA019101
USA PA019301

Lightsource UK/EU E27, Max 60W USA E26, Max 10W
Recommended bulb: Compact LED Bulbs 400 - 1000 Lumen output and from 2700K (for warmer with more colour) up to 6000K (daylight)
Shade aperture measures Ø 5cm / 2"
Cable 4m / 157.5", White Cable
Ceiling Rose White

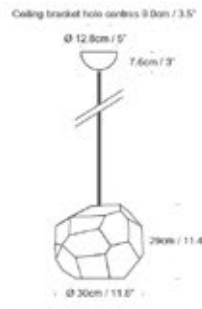

Asteroid PENDANT GLASS - UK/EU PA0291XX
USA PA0293XX

Lightsource UK/EU E27, Max 60W USA E26, Max 10W
Recommended bulb: Compact LED filament or soft tone style 2200-2700K with output 300-500 Lumen
Shade aperture measures Ø 7cm / 2.75"
Cable 4m / 157.5", Clear Cable
Ceiling Rose Chrome

E27 LED Filament style bulbs will bring out the qualities of the glass.
Best performance would be up to 600 Lumen Output with temperature 2200K - 2700K. A great lower light ambient effect can be achieved by using a mirror cap LED bulb.

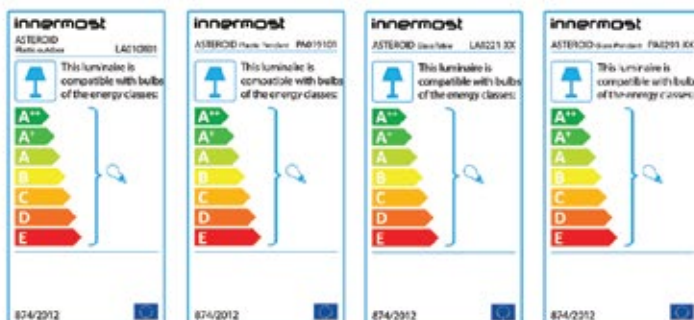

Beads by Winnie Lui

Product Category Pendant
 Material Stainless Steel & Polycarbonate



Please specify colour code 'XX'.
 01-White/ 03-Chrome/ 07-Copper/ 31-Gunmetal

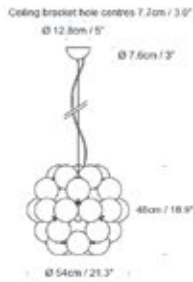

Beads PENTA - UK/EU PB039140XX
 USA PB039340XX

Lightsource UK/EU E27, Max 100W USA E26, Max 15W
 Recommended bulb: Beads works with a variety of different LED bulbs***

Cable 4m / 157.5", Clear Cable

Ceiling Rose Colour matches pendant colour

Other Heavy product, handle with caution

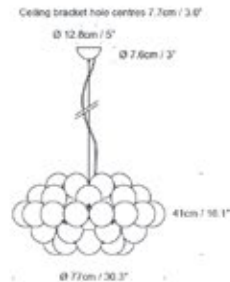

Beads OCTO - UK/EU PB039150XX
 USA PB039350XX

Lightsource UK/EU E27, Max 100W USA E26, Max 15W
 Recommended bulb: Beads works with a variety of different LED bulbs***

Cable 4m / 157.5", Clear Cable

Ceiling Rose Colour matches pendant colour

Other Heavy product, handle with caution

E27 LED Globe Bulbs
 500 - 800 Lumen output and from 2700K - 3000K colour temperature.
 These styles are particularly effective in the white colour and in the metallic options for a softer less reflective look.

E27 LED Filament style bulbs
 will bring out the reflective qualities of the metallic finishes brilliantly.
 Best performance would be from 600-900 Lumen Output with temperature 2200K - 2700K.

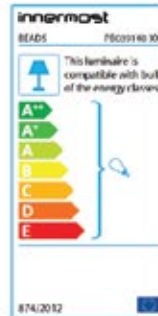

Bolt by Steve Jones

Product Category Wall Light
Material Aluminium

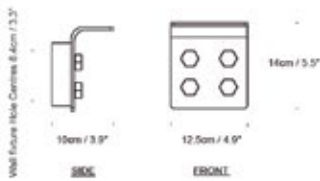

Bolt - UK/EU WB078101
USA WB078301

Lightsource Integrated LED Source,
Sharp Chip, chip life 30,000 hours
13W, 1150lm, 3000K, CRI (Ra) 93
Beam Angle 120°
EU Dimmable via leading/trailing-edge + TRIAC dimmer
US Dimmable via 0-10v + TRIAC dimmer

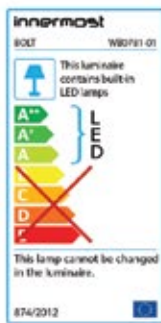

Boule by innermost

Product Category Pendant
Material Steel



Please specify colour code 'XX'.
01-White/ 02-Black/ 03-Chrome/ 07-Copper

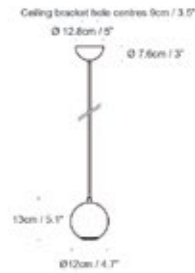

Boule - UK/EU PB069105XX
USA PB069305XX

Lightsource GU10,
UK/EU, Max 25W USA, Max 5W
Recommended bulb:
Any GU10 LED bulb with 5cm / 2" and height ≤6.2cm / 2.4"
is suitable for this fitting

Cable 4m / 157.5"
Boule in white colour has white braided cable,
the other colours come with black braided cable

Ceiling Rose Colour matches pendant colour

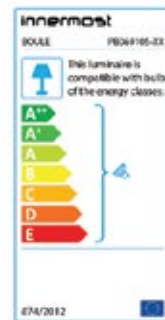

Bracket by Steve Jones

Product Category Wall Light
Material Aluminium

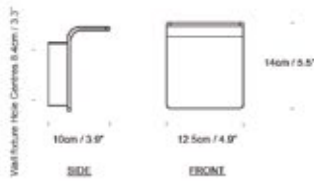

Bracket - UK/EU WB088101
 USA WB088301

Lightsources Integrated LED Source,
 Sharp Chip, chip life 30,000 hours
 13W, 1150lm, 3000K, CRI (Ra) 93
 Beam Angle 120°
 EU Dimmable via leading/ trailing-edge + TRIAC dimmer
 US Dimmable via 0-10v + TRIAC dimmer

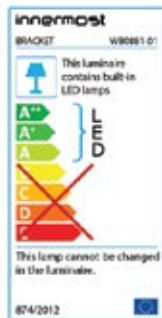

Bric-a-Brac by Deborah Bowness

Product Category Shade
Material Digitally printed wallpaper

*supplied as shade only
 *shades interchangeable between pendant and base

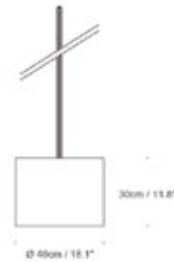

Bric-a-Brac 46 - SDB19130

Lightsources UK/EU, Max 100W USA, Max 15W
 Recommended bulb: LED Globe Bulbs 400 - 1000 Lumen output
 and from 2700K (for warmer with more colour) up to 6000K (daylight)

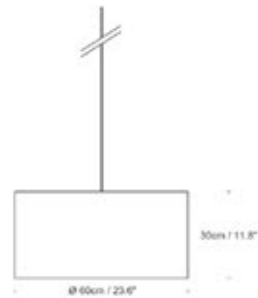

Bric-a-Brac 60 - SDB19140

Lightsources UK/EU, Max 100W USA, Max 15W
 Recommended bulb: LED Globe Bulbs 400 - 1000 Lumen output
 and from 2700K (for warmer with more colour) up to 6000K (daylight)

Bubble by Steve Jones

Product Category Pendant
Material Steel



Please specify colour code 'XX'.
01-White/ 02-Black/ 03-Chrome/
07-Copper/ 62-Black&Copper/



Bubble - UK/EU PBO59105XX
USA PBO59305XX

Lightsource GU10
UK/EU, Max 25W USA, Max 5W
Recommended bulb:
Any GU10 LED bulb with 85cm / 2" and height ≤6.2cm / 2.4"
is suitable for this fitting

Cable 4m / 157.5"
Bubble in white colour has white braided cable,
the other colours come with black braided cable

Ceiling Rose Colour matches pendant colour

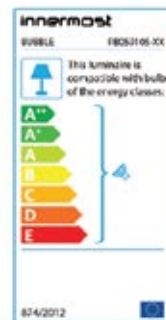

Buckle by Tina Leung

Product Category Pendant
Material Mirror polished stainless steel & white powder coat
*supplied with lightsource



Buckle 70 - UK/EU PBO4914504
USA PBO4934504

Lightsource Integrated LED Source, Optiled AR111
Lumileds chip, chip life 35,000 hours
15.5W, 800lm, 2800K, CRI (Ra) 80
Beam Angle 20°
EU Dimmable via TRIAC dimmer
UL Dimmable via PWM, 0-10v, Resistance dimmer

Cable 7m / 275.6", White Cable

Ceiling Rose Powder coated white

Other Heavy product, handle with caution

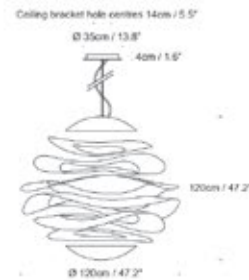

Buckle 120 - UK/EU PBO4917004
USA PBO4937004

Lightsource Integrated LED Source, Optiled AR111
Lumileds chip, chip life 35,000 hours
15.5W, 800lm, 2800K, CRI (Ra) 80
Beam Angle 20°
EU Dimmable via TRIAC dimmer
UL Dimmable via PWM, 0-10v, Resistance dimmer

Cable 7m / 275.6", White Cable

Ceiling Rose Powder coated white

Other Heavy product, handle with caution

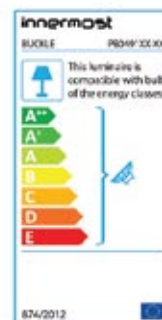

Circus by Corinna Warm

Product Category Pendant/ Wall light
Material Aluminium

-  White with Antique Gold Interior-01
-  Black with Antique Gold Interior-02
-  Grey with Matt White Interior-04

Please specify colour code 'XX'.
01-White with Antique Gold Interior/ 02-Black with Antique Gold Interior/ 04-Gray with Matt White Interior

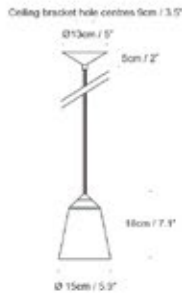

Circus 15 - UK/EU PC049120XX
USA PC049320XX

Lightsource UK/EU E27, Max 60W USA E26, Max 10W
Recommended bulb: LED Globe Bulbs
400 - 1000 Lumen output and from
2700K (for warmer with more colour)
up to 6000K (daylight)

Cable 4m / 157.5",
Circus in black comes with black braided cable,
the other colours comes with white braided cable

Ceiling Rose Colour matches pendant exterior colour

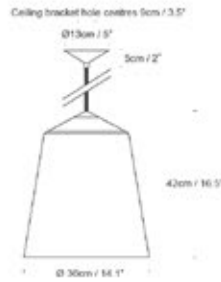

Circus 36 - UK/EU PC049140XX
USA PC049340XX

Lightsource UK/EU E27, Max 100W USA E26, Max 15W
Recommended bulb: LED Globe Bulbs
400 - 1000 Lumen output and from
2700K (for warmer with more colour)
up to 6000K (daylight)

Cable 4m / 157.5",
Circus in black comes with black braided cable,
the other colours comes with white braided cable

Ceiling Rose Colour matches pendant exterior colour

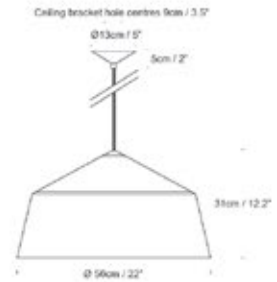

Circus 56 - UK/EU PC049160XX
USA PC049360XX

Lightsource UK/EU E27, Max 100W USA E26, Max 15W
Recommended bulb: LED Globe Bulbs
400 - 1000 Lumen output and from
2700K (for warmer with more colour)
up to 6000K (daylight)

Cable 4m / 157.5",
Circus in black comes with black braided cable,
the other colours comes with white braided cable

Ceiling Rose Colour matches pendant exterior colour

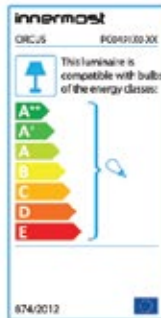

*** with reference to the pendants only
Circus can also be used with E27 LED Filament style bulbs. This will bring out the warm tones of the gold interior on the Black and White versions and add a retro feel to the Grey option. Best performance would be from 600-900 Lumen Output with temperature 2200K - 2700K



*wall light supplied with lightsource

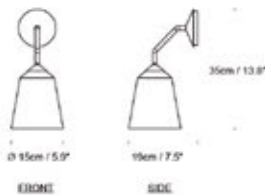

Circus WALL SINGLE - UK/EU WC048120XX
USA WC048320XX

Lightsource UK/EU: Integrated LED Source, AC LED COB
Paragon chip, chip life 40,000 hours
7W, 535lm, 3000K, CRI (Ra) 80
Beam Angle 150°

USA: Integrated LED Source 5w 500lm
CRI (Ra) 80, Beam Angle 150°
0-10v dimmable

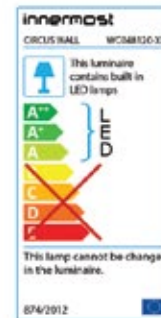

Innermost WEEE registration number WEE/FH1713VS
For max wattages and colour temperatures refer to P.185

Cobra by innermost

Product Category Wall light
 Material Steel, Aluminium, Leather



*supplied with lightsource

Please specify colour code 'XX'.

01-White

(White leather upholstery, White inner hood, White semi-glass switch box)

10-Brown

(Brown leather upholstery, Gold anodised aluminium inner hood, Black semi-glass switch box)

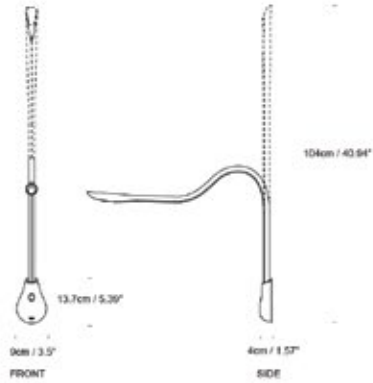

Cobra 90 - UK/EU WC078190XX

Lightsource Integrated LED Source,
 Philips chip, chip life 40,000 hours
 3W, 160lm, 3000K, CRI (Ra) 80
 Beam Angle 160°

Other Cosmetic plate optional for UK/EU
 USB output 1.2A

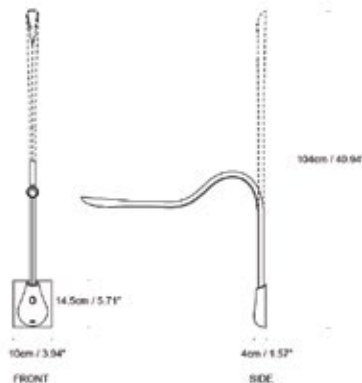

Cobra 90 (UL version) - USA WC078390XX

Lightsource Integrated LED Source,
 Philips chip, chip life 40,000 hours
 3W, 160lm, 3000K, CRI (Ra) 80
 Beam Angle 160°

Other USB output 1.2A

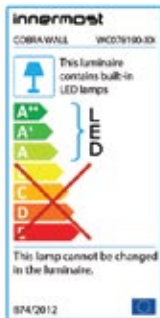

Core by Steve Jones and Frankie Chan

Product Category Pendant
Material Glass



Please specify colour code 'XX'.
00-Clear/ 05-Smoke

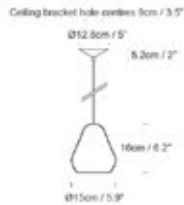

Core 15 - UK/EU PC089105XX
USA PC089305XX

Lightsource UK/EU E27, Max 60W USA E26, Max 10W
Recommended Bulb: Filament or pearl LED Globe Bulbs with 300 - 500 Lumen output each and 2700K (for warmer with more colour). We recommend dimmable bulbs.

Cable 4m / 157.5", Core in clear glass is supplied with white braided cable while Core in smoked glass is supplied with black braided cable.

Ceiling Rose Core in clear glass is supplied with white ceiling rose
Core in smoked glass is supplied with black ceiling rose

Cork by innermost

Product Category Shade
Material Natural Cork backed onto PVC, Powder coated Steel



Please specify colour code 'XX'.
05-Smoke/ 06-Natural
*supplied as shade only
*shades interchangeable between pendant and base



Cork 20*40 - SC059120XX

Lightsource UK/EU, Max 40W USA, Max 8W
Recommended bulb: LED Globe Bulbs 400 - 1000 Lumen output and from 2700K (for warmer with more colour) up to 6000K (daylight)



Core 20 - UK/EU PC089110XX
USA PC089310XX

Lightsource UK/EU E27, Max 60W USA E26, Max 10W
Recommended Bulb: Filament or pearl LED Globe Bulbs with 300 - 500 Lumen output each and 2700K (for warmer with more colour). We recommend dimmable bulbs.

Cable 4m / 157.5", Core in clear glass is supplied with white braided cable while Core in smoked glass is supplied with black braided cable.

Ceiling Rose Core in clear glass is supplied with white ceiling rose
Core in smoked glass is supplied with black ceiling rose



Cork 46*30 - SC059130XX

Lightsource UK/EU, Max 100W USA, Max 15W
Recommended bulb: LED Globe Bulbs 400 - 1000 Lumen output and from 2700K (for warmer with more colour) up to 6000K (daylight)

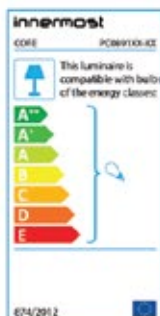

Dent by Chak

Product Category Shade
Material Polyethylene, Synthetic Wadding



*supplied as shade only

Please specify colour code 'XX'.
 01- White/ 15-Gold

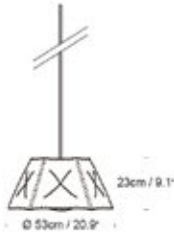

Dent 53 - SD039150XX

Lightsource UK/EU, Max 100W USA, Max 15W
 Recommended bulb: LED Globe Bulbs
 400 - 1000 Lumen output and from 2700K (for warmer with more colour) up to 6000K (daylight)



Dent 80 - SD039160XX

Lightsource UK/EU, Max 100W USA, Max 15W
 Recommended bulb: LED Globe Bulbs
 400 - 1000 Lumen output and from 2700K (for warmer with more colour) up to 6000K (daylight)

 Dent can also used with LED Filament style bulbs for a great retro effect.
 This would be particularly effective in the gold version.

Drop by innermost

Product Category Pendant
Material Glass, Powder coated steel

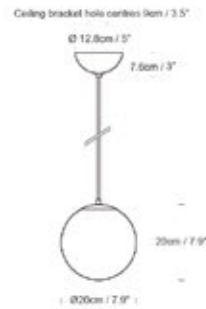

Drop - UK/EU PD04911001
 USA PD04931001

Lightsource UK/EU E27, Max 100W USA E26, Max 15W
 Recommended bulb: LED Globe Bulbs
 400 - 1000 Lumen output and from 2700K (for warmer with more colour) up to 6000K (daylight)

Cable 4m / 157.5", White Cable
Ceiling Rose White

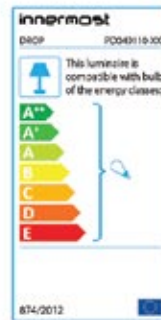

Facet by Tom Kirk

Product Category Pendant/ Wall Light
Material Stainless Steel, Brass



*supplied with lightsource

Please specify colour code 'XX'.
 03-Polished Stainless Steel/ 30-Brass

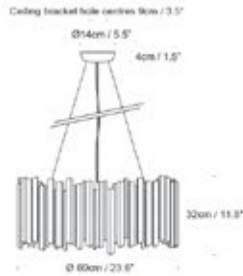

Facet 60 - UK/EU PF039140XX
 USA PF039340XX

Lightsource 12 X G9
 Recommended bulb: For 60, 100 and Lozenge use LED bulbs of around 300 - 350 Lumens output, dimmable

Cable 4m / 157.5", Clear Cable

Ceiling Rose Colour matches pendant colour

Other Heavy product, handle with caution



Facet 18 - UK/EU PF039110XX
 USA PF039310XX

Lightsource G9
 Recommended bulb: G9 LED Bulb up to 350 Lumen output, dimmable.

Cable 4m / 157.5", Clear Cable

Ceiling Rose Colour matches pendant colour

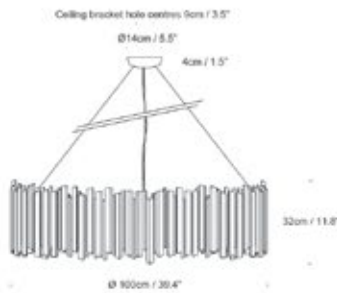

Facet 100 - UK/EU PF039180XX
 USA PF039360XX

Lightsource 24 X G9
 Recommended bulb: For 60, 100 and Lozenge use LED bulbs of around 300 - 350 Lumens output, dimmable

Cable 4m / 157.5", Clear Cable

Ceiling Rose Colour matches pendant colour

Other Heavy product, handle with caution

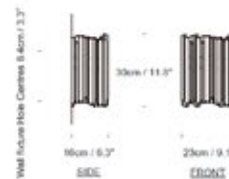

Facet WALL - UK/EU WF039120XX
 USA WF039320XX

Lightsource 2 X G9
 Recommended bulb: G9 LED Bulb up to 350 Lumen output, dimmable.

 Temperature 2700K or below is recommended as the optimum for this fixture.

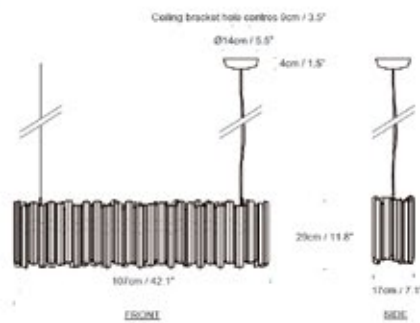

Facet LOZENGE 107 - UK/EU PF039161XX
 USA PF039361XX

Lightsource 6 X G9
 Recommended bulb: For 60, 100 and Lozenge use LED bulbs of around 300 - 350 Lumens output, dimmable

Cable 4m / 157.5", Clear Cable

Ceiling Rose Colour matches pendant colour

Other Heavy product, handle with caution

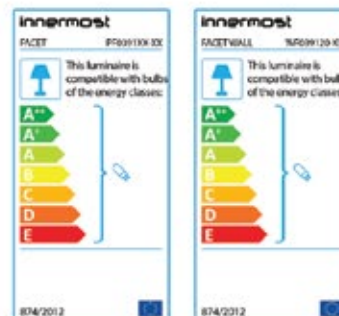

Gable by Jarrod Lim

Product Category Pendant
Material Aluminium & polycarbonate



*supplied with lightsource

Please specify colour code 'XX'.
 01-White/ 08-Red

UK/EU

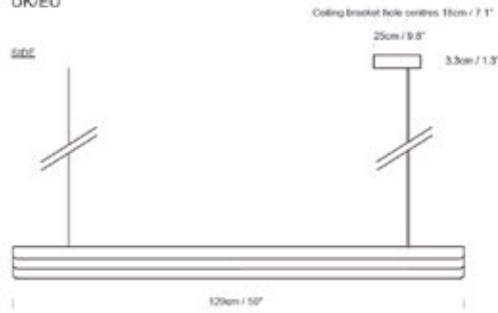

Gable - UK/EU PG0391XX

Lightsource Integrated LED Source,
 Epistar chip, chip life 25,000 hours
 18W, 2300lm, 4000K, CRI (Ra)>80
 Beam Angle 320°
 Dimmable via 0-10v + TRIAC dimmer

Cable 4m / 157.5", White Cable

Ceiling Rose White

USA

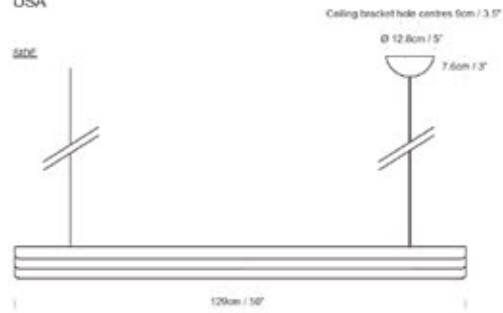

Gable - USA PG0393XX

Lightsource Integrated LED Source,
 Epistar chip, chip life 25,000 hours
 18W, 2300lm, 4000K, CRI (Ra)>80
 Beam Angle 320°
 Dimmable via 0-10v + TRIAC dimmer

Cable 4m / 157.5", White Cable

Ceiling Rose White

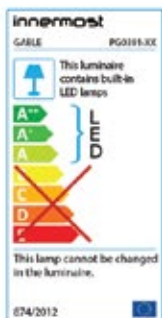

Glaze by Corinna Warm

Product Category Pendant
Material Aluminium



Cream & Copper-07



Black & Charcoal-51

Please specify colour code 'XX'.
07-Cream & Copper/ 51-Black & Charcoal

Ceiling bracket hole centres 9cm / 3.5"

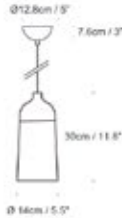

Glaze 14 - UK/EU PG019110XX
USA PG019310XX

Lightsource UK/EU E27, Max 40W USA E26, Max 8W
Recommended bulb: LED Globe Bulbs 400 - 1000 Lumen output and from 2700K (for warmer with more colour) up to 6000K (daylight)

Cable 4m / 157.5", Glaze in black comes with black cable, and the other colours come with clear cable

Ceiling rose Glaze in Cream & Copper comes with a matching cream coloured ceiling rose, Glaze in Black & Charcoal comes with a black ceiling rose.

Ceiling bracket hole centres 9cm / 3.5"

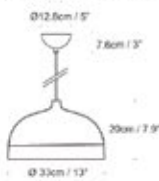

Glaze 33 - UK/EU PG019140XX
USA PG019340XX

Lightsource UK/EU E27, Max 100W USA E26, Max 15W
Recommended bulb: LED Globe Bulbs 400 - 1000 Lumen output and from 2700K (for warmer with more colour) up to 6000K (daylight)

Cable 4m / 157.5", Glaze in black comes with black cable, and the other colours come with clear cable

Ceiling Rose Glaze in Cream & Copper comes with a matching cream coloured ceiling rose, Glaze in Black & Charcoal comes with a black ceiling rose.

Ceiling bracket hole centres 9cm / 3.5"

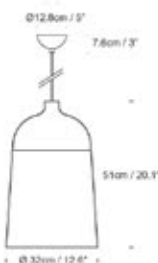

Glaze 32 - UK/EU PG019150XX
USA PG019350XX

Lightsource UK/EU E27, Max 100W USA E26, Max 15W
Recommended bulb: LED Globe Bulbs 400 - 1000 Lumen output and from 2700K (for warmer with more colour) up to 6000K (daylight)

Cable 4m / 157.5", Glaze in black comes with black cable, and the other colours come with clear cable

Ceiling Rose Glaze in Cream & Copper comes with a matching cream coloured ceiling rose, Glaze in Black & Charcoal comes with a black ceiling rose.

Ceiling bracket hole centres 9cm / 3.5"

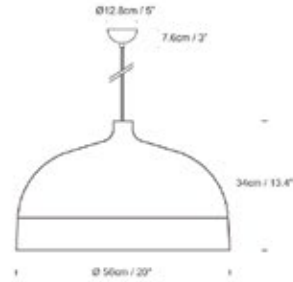

Glaze 56 - UK/EU PG019180XX
USA PG019380XX

Lightsource UK/EU E27, Max 100W USA E26, Max 15W
Recommended bulb: LED Globe Bulbs 400 - 1000 Lumen output and from 2700K (for warmer with more colour) up to 6000K (daylight)

Cable 4m / 157.5", Glaze in black comes with black cable, and the other colours come with clear cable

Ceiling Rose Glaze in Cream & Copper comes with a matching cream coloured ceiling rose, Glaze in Black & Charcoal comes with a black ceiling rose.

Glaze can also used with E27 LED Filament style bulbs, which will bring out the warm tones of the copper finish or provide contrast on the Black and Graphite version.

Best performance would be from 600-900 Lumen Output with temperature 2200K - 2700K.

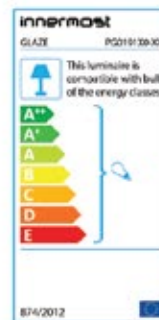

Jeeves & Wooster by Jake Phipps

Product Category Pendant/ Table Lamp/Wall Light
Material Aluminium & Wool felt



Jeeves - UK/EU PJ029102
 USA PJ029302

Lightsource G9,
 UK/EU, Max 25W USA, Max 5W
 Recommended bulb: Any G9 LED Bulb up to 500 Lumen output, dimmable,
 Temperature 2200 - 2700 Kelvin.
Cable 2.4m / 94.5\", Black Braided Cable
Ceiling Rose Black



Jeeves TABLE - UK/EU LJ022102
 USA LJ022302

Lightsource G9,
 UK/EU, Max 25W USA, Max 5W
 Recommended bulb: Any G9 LED Bulb up to 500 Lumen output, dimmable,
 Temperature 2200 - 2700 Kelvin.
Cable 50cm / 19.7\" to switch, 1.5m / 59\" to plug, Black Braided Cable
Switch inline rocker

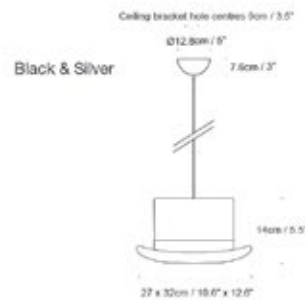

Wooster - UK/EU PW029102
 USA PW029302

Lightsource G9,
 UK/EU, Max 25W USA, Max 5W
 Recommended bulb: Any G9 LED Bulb up to 500 Lumen output, dimmable,
 Temperature 2200 - 2700 Kelvin.
Cable 2.4m / 94.5\", Black Braided Cable
Ceiling Rose Black



Jeeves WALL - UK/EU WJ028102
 USA WJ028302

Lightsource G9,
 UK/EU, Max 25W USA, Max 5W
 Recommended bulb: Any G9 LED Bulb up to 500 Lumen output, dimmable,
 Temperature 2200 - 2700 Kelvin.

Jeeves comes with a Gold Anodized Interior and
 Wooster comes with a Silver Anodized Interior

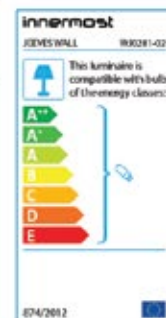
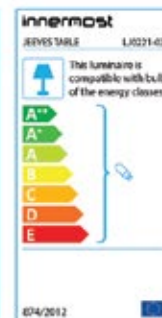
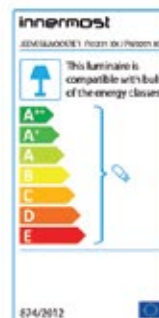

Jelly by Stone Designs

Product Category Pendant
Material Glass



Please specify colour code 'XX'.
05-Grey/ 08-Red/ 12-Blue/ 27-Yellow

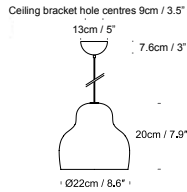

Jelly 22 - UK/EU P.J039110XX
USA P.J039310XX

Lightsource: UK/EU E27, Max 60W USA E26, Max 10W
Recommended Bulb: Filament or pearl LED Globe Bulbs with 300 - 500 Lumen output each and 2700K (for warmer with more colour). We recommend dimmable bulbs.

Cable: 4m / 157.5", Grey Jelly comes with black cable while Jelly Red, Blue and Yellow come with white cable.

Ceiling Rose: Grey Jelly comes with black ceiling rose while Jelly Red, Blue and Yellow come with white ceiling rose.

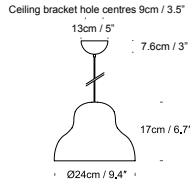

Jelly 24 - UK/EU P.J039105XX
USA P.J039305XX

Lightsource: UK/EU E27, Max 60W USA E26, Max 10W
Recommended Bulb: Filament or pearl LED Globe Bulbs with 300 - 500 Lumen output each and 2700K (for warmer with more colour). We recommend dimmable bulbs.

Cable: 4m / 157.5", Grey Jelly comes with black cable while Jelly Red, Blue and Yellow come with white cable.

Ceiling Rose: Grey Jelly comes with black ceiling rose while Jelly Red, Blue and Yellow come with white ceiling rose.

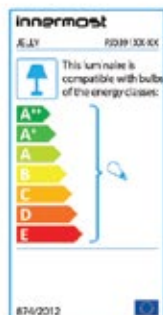

Kapow! by Tina Leung

Product Category Shade
Material Woven Nylon Tubing

*supplied as shade only



Kapow! - UK/EU SK019101
USA SK019301

Lightsource: UK/EU, Max 15W USA, Max 3W
Recommended bulb: LED Globe Bulbs up to 500 Lumen output and from 2700K (for warmer with more colour) up to 6000K (daylight)

Kobe by Russell Cameron

Product Category Shade
 Material Polyester/ 100% Wool

Polyester:



Wool:



Please specify colour code 'XX'

02-Black/ 05-Charcoal/ 06-Natural/ 08-Red/ 09-Purple/ 16-Warm Grey/ 17-Dark Grey/ 18-Ochre/ 29-Red

*supplied as shade only

*shades interchangeable between pendant and base



Kobe 32*26 - SK039110XX

Lightsource UK/EU, Max 60W USA, Max 10W
 Recommended bulb: LED Globe Bulbs 400 - 1000 Lumen output and from 2700K (for warmer with more colour) up to 6000K (daylight)



Kobe 60*30 - SK039140XX

Lightsource UK/EU, Max 100W USA, Max 15W
 Recommended bulb: LED Globe Bulbs 400 - 1000 Lumen output and from 2700K (for warmer with more colour) up to 6000K (daylight)

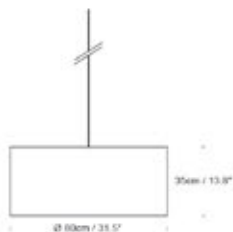

Kobe 80*35 - SK039150XX

Lightsource UK/EU, Max 100W USA, Max 15W
 Recommended bulb: 3 CAE27, LED Globe Bulbs 400 - 1000 Lumen output and from 2700K (for warmer with more colour) up to 6000K (daylight)

Lateralis by Ben McCarthy

Product Category Table Lamp
Material Glass, Dark stained ash wood,
 Anodised Aluminium

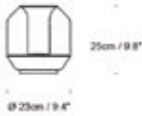

Lateralis - UK/EU LL099127
 USA LL099327

Lightsource G9,
 UK/EU, Max 25W USA, Max 5W
 Recommended bulb: G9 LED Bulb up to 500 Lumen output,
 dimmable. Temperature 2700 - 3000 Kelvin

Cable 30cm/ 11.8" to switch, 80cm/ 31.5" to plug, Black Cable.

Switch Rotary dimmer

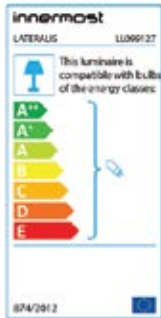
**Latitude** by Flynn Talbot

Product Category Pendant
Material Aluminium & Steel



*supplied with lightsource

Please specify colour code 'XX'.
 01-White/ 02-Black/ 08-Red

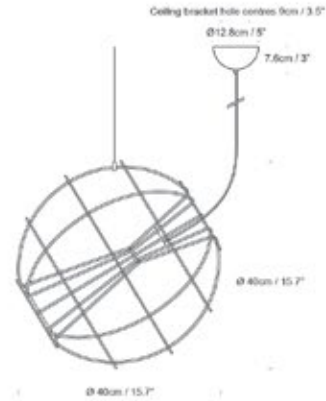

Latitude - UK/EU PL089130XX
 USA PL089330XX

Lightsource Integrated LED Source,
 Cree chip, chip life 30,000 hours
 10W, 850lm, 2700K, CRI (Ra) >82
 Beam Angle 60°
 Dimmable via 0-10v + TRIAC dimmer

Cable 4m/ 157.5"
 Braided cable colour matches product colour

Ceiling Rose Ceiling rose colour matches product colour

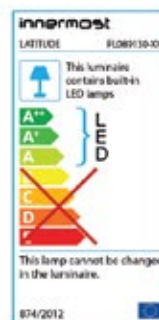

Laurie Grove by Deborah Bowness

Product Category Shade
Material Digitally Printed Wallpaper

*supplied as shade only
 *shades interchangeable between pendant and base



Laurie Grove 46 - SDB39130

Lightsources UK/EU, Max 100W USA, Max 15W
 Recommended bulb: LED Globe Bulbs 400 - 1000 Lumen output
 and from 2700K (for warmer with more colour) up to 6000K (daylight)

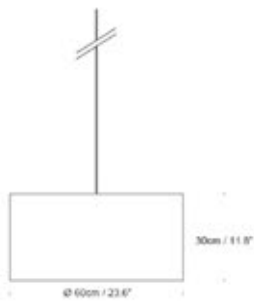

Laurie Grove 60 - SDB39140

Lightsources UK/EU, Max 100W USA, Max 15W
 Recommended bulb: LED Globe Bulbs 400 - 1000 Lumen output
 and from 2700K (for warmer with more colour) up to 6000K (daylight)

Lighthouse by innermost

Product Category Shade/ Wall Light
Material Polycarbonate

*supplied as shade only
 *shades interchangeable between pendant and base

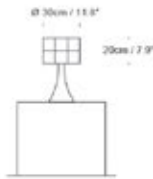

Lighthouse 30*20 - SL02911000

Lightsource Max 100W / North America Max 15W
 Recommended bulb: LED Globe Bulbs 400 - 1000 Lumen output and from 2700K (for warmer with more colour) up to 6000K (daylight)

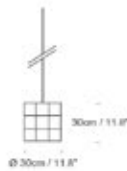

Lighthouse 30*30 - SL02912000

Lightsource UK/EU, Max 100W USA, Max 15W
 Recommended bulb: LED Globe Bulbs 400 - 1000 Lumen output and from 2700K (for warmer with more colour) up to 6000K (daylight)

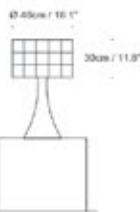
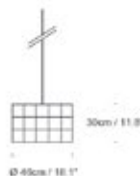

Lighthouse 46*30 - SL02913000

Lightsource UK/EU, Max 100W USA, Max 15W
 Recommended bulb: LED Globe Bulbs 400 - 1000 Lumen output and from 2700K (for warmer with more colour) up to 6000K (daylight)

 Lighthouse can also be used with LED Filament style bulbs for a great retro effect.

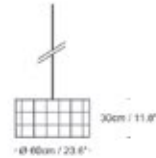

*comes with diffuser

Lighthouse 60*30 - SL03914500

Lightsource Max 100W / North America Max 15W
 Recommended bulb: LED Globe Bulbs 400 - 1000 Lumen output and from 2700K (for warmer with more colour) up to 6000K (daylight)



Lighthouse 60*40 - No Diffuser SL029140
 With Diffuser SL039140

Lightsource UK/EU, Max 100W USA, Max 15W
 Recommended bulb: LED Globe Bulbs 400 - 1000 Lumen output and from 2700K (for warmer with more colour) up to 6000K (daylight)

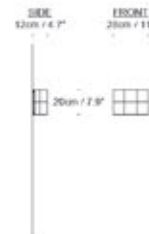

Lighthouse WALL - UK/EU WL028100
 USA WL028300

Lightsource UK/EU, Max 40W USA, Max 8W
 Recommended bulb: compact LED Globe Bulbs 400 - 1000 Lumen output and from 2700K (for warmer with more colour) up to 6000K (daylight)

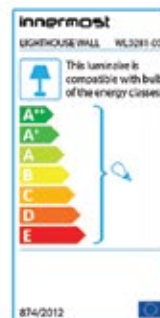

Matrioshka by Stone Designs

Product Category Pendant
Material Glass

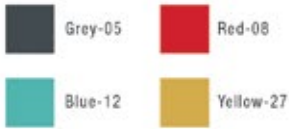

Please specify colour code 'XX'.
05-Grey/ 08-Red/ 12-Blue/ 27-Yellow

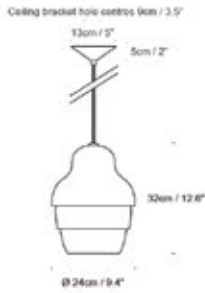

Matrioshka - UK/EU PM0891XX
USA PM0893XX

Lightsource UK/EU E27, Max 100W USA E26, Max 15W
Recommended bulb: LED Globe Bulbs 400 - 1000 Lumen output and from 2700K (for warmer with more colour) up to 6000K (daylight).
Cable 4m / 157.5", White Cable
Ceiling Rose White

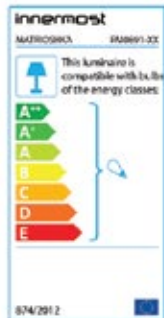

Membrane by Jette Scheib

Product Category Pendant
Material Glass

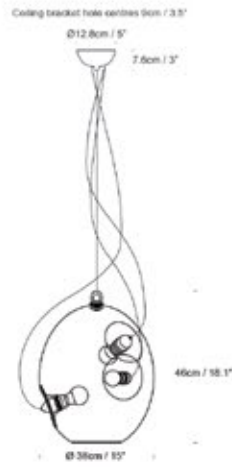

Membrane - UK/EU PM09913005
USA PM09933005

Lightsource UK/EU 3xE27, Max 100W each USA 3xE26, Max 5W each
Recommended Bulb: Filament or pearl LED Globe Bulbs with 400 - 500 Lumen output each and 2700K (for warmer with more colour). We recommend dimmable bulbs.
Cable 4m / 157.5", Black Cable
Ceiling Rose Gunmetal
Other Heavy product, handle with caution.

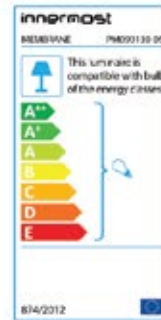

Metallic by Innermost

Product Category Shade
Material Laminated Cast Vinyl



Please specify colour code 'XX'
11-Orange/ 12-Blue/ 13-Green/ 14-Pink

*supplied as shade only
*shades interchangeable between pendant and base

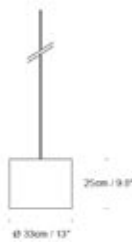

Metallic 33*25 - SPR110XX

Lightsource UK/EU, Max 60W USA, Max 10W
Recommended bulb: LED Globe Bulbs 400 - 1000 Lumen output and from 2700K (for warmer with more colour) up to 6000K (daylight)

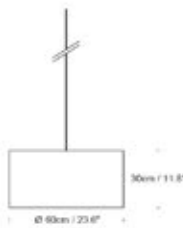

Metallic 60*30 - SPR140XX

Lightsource UK/EU, Max 100W USA, Max 15W
Recommended bulb: LED Globe Bulbs 400 - 1000 Lumen output and from 2700K (for warmer with more colour) up to 6000K (daylight)

MnM by Steve Jones

Product Category Shade
Material PVC & 100% Wool

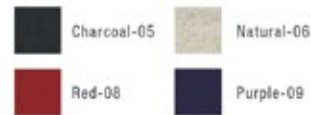

Please specify colour code 'XX'.
05-Charcoal/ 06-Natural/ 08-Red/ 09-Purple

*supplied as shade only

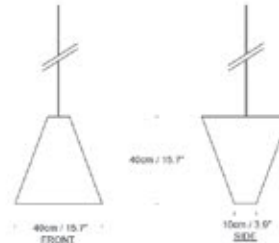

MnM 40 - SM039128XX

Lightsource UK/EU, Max 60W USA, Max 10W
Recommended bulb: LED Globe Bulbs 400 - 1000 Lumen output and from 2700K (for warmer with more colour) up to 6000K (daylight)

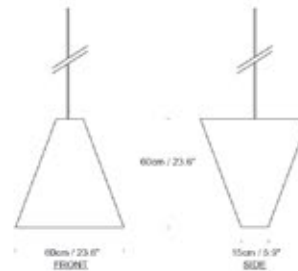

MnM 60 - SM039140XX

Lightsource UK/EU, Max 60W USA, Max 10W
Recommended bulb: LED Globe Bulbs 400 - 1000 Lumen output and from 2700K (for warmer with more colour) up to 6000K (daylight)

Moscow Graffiti by Deborah Bowness

Product Category Shade
Material PVC & 100% Wool

**Moscow Graffiti 46** - SDB29130

Lightsources UK/EU, Max 100W USA, Max 15W
 Recommended bulb: LED Globe Bulbs 400 - 1000 Lumen output
 and from 2700K (for warmer with more colour) up to 6000K (daylight)

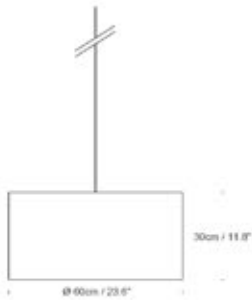
**Moscow Graffiti 60** - SDB29140

Lightsources UK/EU, Max 100W USA, Max 15W
 Recommended bulb: LED Globe Bulbs 400 - 1000 Lumen output
 and from 2700K (for warmer with more colour) up to 6000K (daylight)

Parasol by Jonas Forsman

Product Category Table Lamp
Material Steel



*supplied with lightsource

Please specify colour code 'XX'.
01-White/ 02-Black/ 08-Red

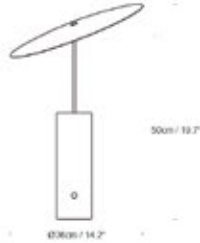

Parasol - UK/EU LP0591XX
USA LP0593XX

Lightsource Integrated LED Source, Sharp chip, chip life 30,000 hours
3x5W, 1200lm, 2700K, CRI (Ra)>82
Beam Angle 120°
Dimmable

Cable 1.5m/ 59.1" to plug, White Braided Cable

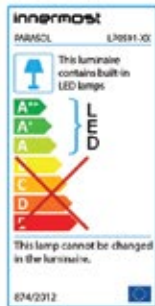

Pomelo by Stone Designs

Product Category Pendant
Material Glass

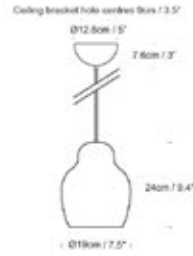

Pomelo - UK/EU PPO6911001
USA PPO6931001

Lightsource UK/EU E27, Max 60W USA E26, Max 10W
Recommended bulb: LED Globe Bulbs 400 - 1000 Lumen output
and from 2700K (for warmer with more colour) up to 6000K (daylight).

Cable 4m / 157.5", White Cable

Ceiling Rose White

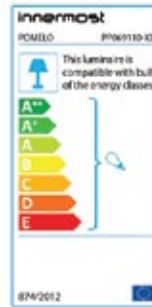

Portland by James Bartlett

Product Category Pendant
Material Natural Concrete and Coloured Interior



Please specify colour code 'XX'.
 01-White/ 08-Red/ 28-Aqua

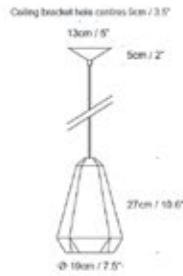

Portland 19 - UK/EU LP039120XX
 USA LP039320XX

Lightsource GU10, UK/EU, Max 25W USA, Max 5W
 Recommended bulb: Any GU10 LED bulb is suitable for this fitting

Cable 4m / 157.5", White Cable

Ceiling Rose White

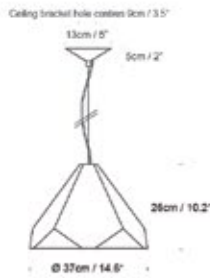

Portland 37 - UK/EU LP019130XX
 USA LP019330XX

Lightsource UK/EU E27, Max 100W USA E26, Max 15W
 Recommended bulb: LED Globe Bulbs 400 - 1000 Lumen output
 and from 2700K (for warmer with more colour) up to 6000K (daylight)

Cable 4m / 157.5", White Cable

Ceiling Rose White



Portland Plaster by James Bartlett

Product Category Pendant
Material Plaster

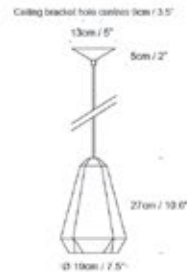

Portland PLASTER 19 - LP01912001

Lightsource GU10, UK/EU, Max 25W USA, Max 5W
 Recommended bulb: Any GU10 LED bulb is suitable for this fitting

Cable 4m / 157.5", White Cable

Ceiling Rose White

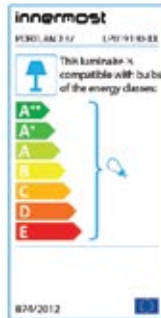
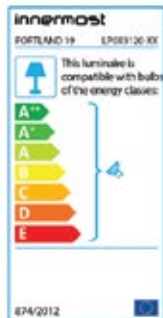

RD2SQ by Steve Jones

Product Category Shade/ Table & Floor Lamp
Material Steel, Acrylic, Polyester



Please specify colour code 'XX'.
02-Black/ 16-Warm Grey/ 17-Dark Grey/ 18-Ochre
*supplied as shade only



RD2SQ SHORT 40 - SR019128XX

Lightsource UK/EU, Max 100W USA, Max 15W
Recommended bulb: LED Globe Bulbs 400 - 1000 Lumen output and from 2700K (for warmer with more colour) up to 6000K (daylight)



RD2SQ TALL 40 - SR019130XX

Lightsource UK/EU, Max 100W USA, Max 15W
Recommended bulb: LED Globe Bulbs 400 - 1000 Lumen output and from 2700K (for warmer with more colour) up to 6000K (daylight)



RD2SQ 60 - SR019145XX

Lightsource UK/EU, Max 100W USA, Max 15W
Recommended bulb: LED Globe Bulbs 400 - 1000 Lumen output and from 2700K (for warmer with more colour) up to 6000K (daylight)

RD2SQ- TABLE & FLOOR

Please specify base colour code 'YY'.



*unit includes base and shade

RD2SQ FLOOR - UK/EU LR02111YXX
USA LR02131YXX

Lightsource UK/EU E27, Max 100W USA E26, Max 15W
Recommended bulb: LED Globe Bulbs 400 - 1000 Lumen output and from 2700K (for warmer with more colour) up to 6000K (daylight)
Cable 60cm / 23.6" to switch, 1.5m / 59.1" to plug; Clear Cable
Switch Floor switch

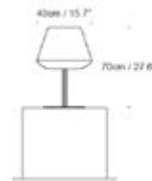
RD2SQ TABLE - UK/EU LR02211YXX
USA LR02231YXX

Lightsource UK/EU E27, Max 100W USA E26, Max 15W
Recommended bulb: LED Globe Bulbs 400 - 1000 Lumen output and from 2700K (for warmer with more colour) up to 6000K (daylight)
Cable 45cm / 17.1" to switch, 1.5m / 59.1" to plug; Clear Cable
Switch inline rocker

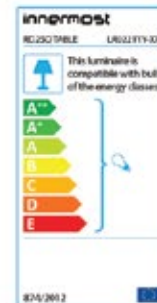
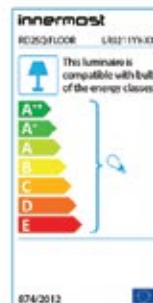

Snowdrop by Stone Designs

Product Category Pendant
Material Aluminium & Glass



Please specify colour code 'XX'.
09-Purple/ 11-Orange/ 13-Green
14-Pink/ 27-Yellow/ 28-Aqua

Ceiling bracket hole centres from 135"

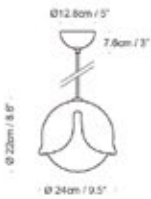

Snowdrop - UK/EU PSD69110XX
USA PSD69310XX

Lightsource UK/EU E27, Max 100W USA E26, Max 15W
Recommended bulb: LED Globe Bulbs 400 - 1000 Lumen output and
from 2700K (for warmer with more colour) up to 6000K (daylight).
Cable 4m / 157.5", braided cable colour matches with product colour
Ceiling Rose ceiling rose colour matches with product colour

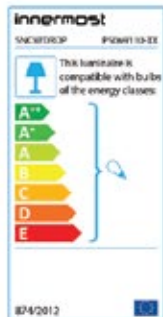

Stupa by Freshwest

Product Category Pendant
Material Resin



Please specify colour code 'XX'.
01-White/ 06-Yellow

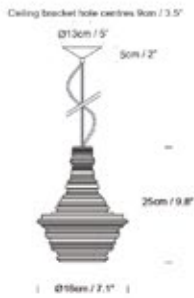

Stupa 18 - UK/EU PS079110XX
USA PS079310XX

Lightsource UK/EU E27, Max 100W USA E26, Max 15W
Recommended bulb: LED Globe Bulbs 400 - 1000 Lumen output and from 2700K (for warmer with more colour) up to 6000K (daylight).

Cable 4m / 157.5"
Stupa White is supplied with white braided cable, while Stupa Yellow is supplied with red braided cable.

Ceiling Rose White

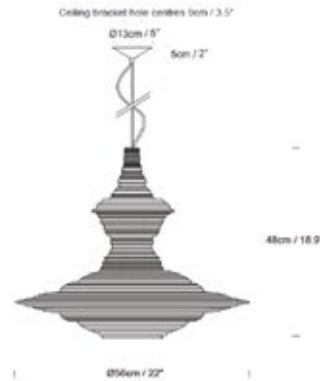

Stupa 56 - UK/EU PS079140XX
USA PS079340XX

Lightsource UK/EU E27, Max 100W USA E26, Max 15W
Recommended bulb: LED Globe Bulbs 400 - 1000 Lumen output and from 2700K (for warmer with more colour) up to 6000K (daylight).

Cable 4m / 157.5"
Stupa White is supplied with white braided cable, while Stupa Yellow is supplied with red braided cable.

Ceiling Rose White

Other Heavy product, handle with caution

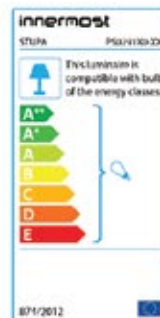

YOYLight by YOY

Product Category Table Lamp
Material Aluminium & Steel



YOYLight UK - LY012001
YOYLight EU - LY012201
YOYLight US - LY012301

Lightsource Integrated LED Source,
Cree chip, chip life 30,000 hours
3W, 100lm, 4000K, CRI (Ra)>80
Beam Angle 120°
Cable 50cm / 19.7\" to switch, 1.5m/ 59.1\" to plug. White Cable
Switch inline rocker

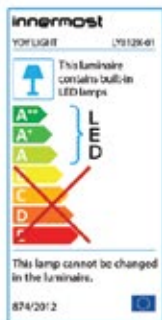

YOYWall by YOY

Product Category Wall Light
Material Aluminium & Steel

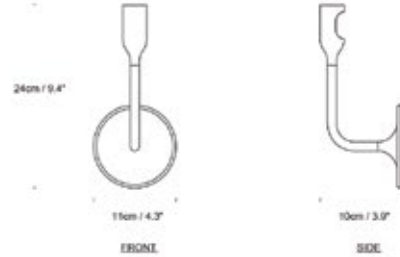

YOYWall - UK/EU WY018101
USA WY018301

Lightsource Integrated LED Source,
Cree chip, chip life 30,000 hours
3W, 100lm, 4000K, CRI (Ra)>80
Beam Angle 120°
Other Driver must be housed inside wall cavity

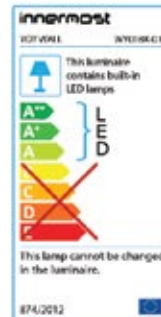

Tripod Base by innermost

Product Category Base
Material Steel

SN Satin Nickel-04



Tripod Base 35 - UK/EU BT012104
USA BT011304

Lightsource UK/EU E14, Max 60W USA, Max 10W
Cable 80cm / 31.5" to switch, 1.5m / 59" to plug,
Clear cable.
Switch inline rocker

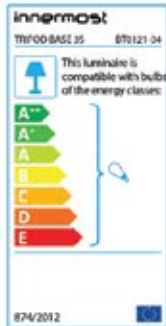

Tripod Base FLOOR - UK/EU BT011104
USA BT011304

Lightsource UK/EU E27, Max 100W USA, Max 15W
Cable 1.5m / 59.1" to switch, 1.5m / 59" to plug,
Clear cable.
Switch Foot switch

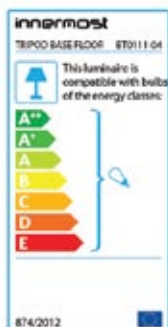

Trumpet Base by innermost

Product Category Base
Material Steel

White-01 Black-02
Chrome-03

Please specify colour code 'XX'.
01-White/ 02-Black/ 03-Chrome
*Trumpet Base 35 is not available in Black



Trumpet Base 35 - UK/EU BT0221XX
USA BT0223XX

Lightsource UK/EU E27, Max 100W USA E26, Max 15W
Cable 40cm / 15.7" to switch, 1.5m / 59" to plug,
Clear Cable.
Switch inline rocker

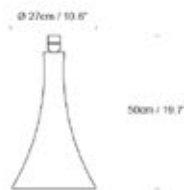

Trumpet Base 50 - UK/EU BT0321XX
USA BT0323XX

Lightsource UK/EU E27, Max 100W USA E26, Max 15W
Cable 30cm / 11.8" to switch, 1.5m / 59" to plug,
Clear Cable.
Switch inline rocker

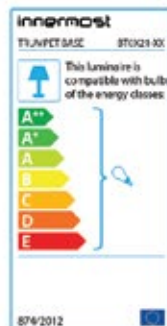

Pendant Fittings

Product Category Fittings
Material Steel

White-01 **SN** Satin Nickel-04

Please specify colour code 'XX'.
01-White/ 04-Satin Nickel



3CAE27 - UK/EU EC0291XX
3CAE26 - USA EC0293XX

Lightsource UK/EU 3 x E27, Max 100W each USA 3 x E26, Max 15W each
Cable 4m / 157.5", Clear Cable



*CAE27 is only available in Satin Nickel

CAE27 - UK/EU EC059104
CAE26 - USA EC059304

Lightsource UK/EU E27, Max 100W USA E26, Max 15W
Cable 1.8m / 70.9", Clear Cable



*CAE27 is only available in Satin Nickel

CAE27 - UK/EU EC049104
CAE26 - USA EC049304

Lightsource UK/EU E27, Max 100W USA E26, Max 15W
Cable 4m / 157.5", Clear Cable

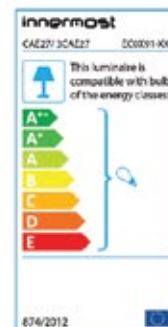

Below is a table that shows typical lumen output for common incandescent bulbs and their equivalents.

Minimum light output (lumens)	Electrical power consumption (watts)		
	Incandescent	Halogen	Compact Fluorescent
450	40	28	9-11
800	60	42	13-15
1,100	75	53	18-20
1,600	100	70	24-28
2,400	150	100	30-52

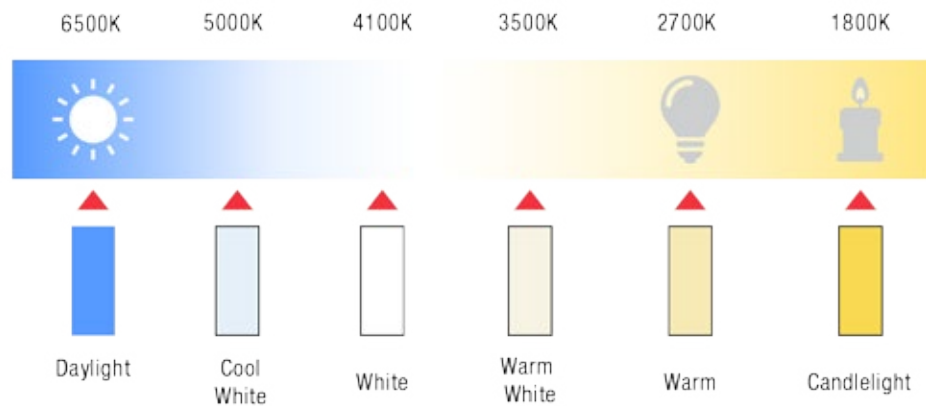

innermost®

Offices

UK/ Ireland/ Europe Office & Showroom

2.02 - 2.04 OXO Tower Wharf
Bargehouse Street, London SE1 9PH
T: +44 (0)20 7620 1808
E: info@innermost.net

Asia Sales Office

Unit 02 & 03, 2/F, EW International Tower
No.120 Texaco Road, Tsuen Wan, Hong Kong
T: +852 2857 5289
E: info@innermost.net

innermost®

Agents & Distributors

Australia

ECC
Unit 24 / 47-51 Lorraine St
Peakhurst, Sydney
NSW 2210 Australia
T: +02 94606600
E: ecc.aus@innermost.net

Baltic Countries

MARIO CASAGRANDE
Viale G. Lacchin, 30
33077 Sacile PN, Italy
T: +39 335 6045 220
E: casagrande@innermost.net

Belgium

BELUCE
Pannenstraat 119
8300 Knokke-Heist, Belgium
T: +32 50 34 61 86
E: beluce@innermost.net

Bosnia, Kosovo, Serbia, Montenegro, Macedonia

ZAMEST INTERNATIONAL TRADE AGENCY
Svetozara Markovića, 68/19
34000 Kragujevac, Serbia
T: +39 335 6744 910
T SRB: +381 62 8793 020
E: zamest@innermost.net

Canada

LIGHTFORM CANADA
267 Niagara St, Toronto,
Ontario, Canada M6J 2L7
T: +1 866 526 7232
E: lightform@innermost.net

Croatia and Slovenia

ZAMEST INTERNATIONAL TRADE
AGENCY
Svetozara Markovića, 68/19
34000 Kragujevac, Serbia
T: +39 335 6744 910
E: zamest@innermost.net

**Czech Republic, Estonia, Hungary
Latvia, Lithuania, Slovakia**

MARIO CASAGRANDE

Viale G. Lacchin, 30
33077 Sacile PN, Italy
T: +39 335 6045 220
E: casagrande@innermost.net

Finland

DECOLIGHT OY

Lapintie 4
33100 Tampere, Finland
T: +35 8 40 5151 785
E: decolight@innermost.net

France

ALGO MÀS

320 Rue Saint-Honoré
75001 Paris, France
T: +33 6 14 47 77 63
E: algomas@innermost.net

Germany

HUBERTUS IGGES HANDELSAGENTUR

Covering German postcodes-
70-74, all 8, all 9
T: +49 171 850 1458
E: igges@innermost.net

ROBERT HEIJLIGERS

Covering German postcodes-
all 4, 50-52, 58-59, 30-33, 37-38
T: +49 1723198028
E: heijligers@innermost.net

STEFFEN KNOPP AGENTUR

Covering German postcodes-
34-36, 53-57, all 6, 75-79
T: +49 171 7772492
E: knopp@innermost.net

Greece & Cyprus

GRUPPO CASA

12, Amazonon str.
55133 Thessaloniki, Greece
T: +30 694 432 5022
E: gruppocasa@innermost.net

Italy

VM CONSULTING

Via Quaglia, 4
48018 Faenza RA, Italy
T: +0039 0546 41630
E: italy@innermost.net

Mexico

INTERIORES 0503

Camino al Olivo no.15 despacho 201
Lomas de Vista Hermosa
Mexico D.F 05100, Mexico
T: +52 (55) 525 33 039
E: interiores@innermost.net

Netherlands

ARTIMETA BV

De Koumen 86
6433 Ke Hoensbroek, Netherlands
T: +31 45 5227722
E: artimeta@innermost.net

New Zealand

ECC LIMITED

39 Nugent Street, Grafton
Auckland, New Zealand
T: +64 9 379 9680
E: ecc.nz@innermost.net

innermost®

Agents & Distributors

Russia Federation

CAROTI & PARTNERS
Krasnopresnenskaya Naberezhnaya,
12 Office 1102 Moscow
T: +7 925 517 27 81 3
E: caroti@innermost.net

Singapore

FLAIR ILLUME
25 Tagore Lane
03-07 Singapore Godown
787602 Singapore
T: +65 96918856
E: flairillum@innermost.net

Spain

ESPACIOARETHA
Claudio Coello, 46
28001 Madrid, Spain
T: +34 918 317 787
E: espacioaretha@innermost.net

Sweden

CIRCLE AGENTURER
Borgmästaregatan 25
43241 Varberg, Sweden
T: +46 7061 08 110
E: circle@innermost.net

Switzerland

TOM FLAVELL
9 rue Gleitz
39100 Champvans, France
T: +33 7897 431 76
E: switzerland@innermost.net

Taiwan

FASHION LIGHTING GROUP
2F., No.120, Sec 4, Minsheng E. Rd
Taipei 105, Tai wan
T: +886 2 2718 5288
E: flg@innermost.net

Ukraine

FERNANDO COLOMBARI AGENCY
Ul. Baumana, 25, office 122
Kiev, Ukraine
T: +38 (044) 400 35 31
E: colombari@innermost.net

USA

IM DESIGN CONCEPTS
57 Saunders Hollow Road
Old Lyme, CT 06371
T: +1 888 899 IMDC (4632)
E: america@innermost.net

